

Fire-Rated Housings

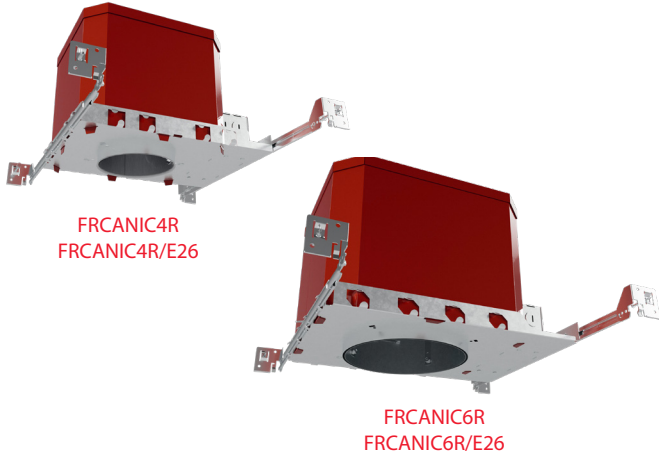

PROJECT:

DATE:

TYPE:

PREPARED BY:



UL-Listed protection for floor/ceiling assemblies.

KEY FEATURES

- E26 socket models accept standard LED bulbs out of the box
- IC rated for direct contact with insulation
- Airtight in accordance to ASTM E283
- Adjustable bar hangers span 13¾" to 24½" for flexible joist spacing
- Compatible with 4" and 6" LED trims for versatile retrofit upgrades



PERFORMANCE

Catalog Number	Depth	Size	Product Type	Input Wattage	Base
FRCANIC4R	5 1/2"	4"	New Construction	120/277V	Quick Connector
FRCANIC4R/E26	5 1/2"	4"	New Construction	120/277V	E26 Edison
FRCANIC6R	7 1/2"	6"	New Construction	120/277V	Quick Connector
FRCANIC6R/E26	7 1/2"	6"	New Construction	120/277V	E26 Edison

TECHNICAL SPECIFICATIONS

CONSTRUCTION

Product Type

Fire Rated Housings

Size

4", 6"

Shape

Round

Housing

Heavy-gauge die-cast steel housing rated for fire-resistance. UL Listed for fire-rated floor/ceiling assembly applications.

Nailer Bars

Two 13-3/4" to 24-1/2" adjustable bar hangers with captive nails are included on frame. Hanger bars have T-Bar slot and alignment feet. Bar hangers are parallel to junction box, but can be repositioned 90° perpendicular to junction box if desired. "L" Shaped bar hanger foot to align to bottom of construction joist. A T-Bar notch allows easy installation in a suspended ceiling.

Junction Box

Prewired 25 cubic inch 0.064" thick galvanized steel box with seven 1/2" trade size knockouts and snap on covers. All leads are #18AWG wire, the ground wire is connected to the bottom, and quick connectors are supplied on all leads. Maximum of 8 no. 12 AWG through branch circuit conductors suitable for at least 90°C permitted in junction box.

Romex Strain Relief

Junction box includes two Romex tabs with two slots at each tab for NM-cables of 12/2 to 14/2. The strain relief allows for easy installation and less materials.

TECHNICAL SPECIFICATIONS *(cont'd)*

COMPLIANCE

Listings

UL Listed, UL Recognized

Environment

Suitable for use indoors and outdoors in dry, damp, or wet environments.

Fire-Rated

Tested to UL 263 and ASTM E119 standards for 2-hour fire resistance

IC Rated

Suitable for direct contact with insulation. Type IC inherently protected, suitable for direct contact to air permeable insulation and cULus listed for damp locations. Not for use in direct contact with spray foam insulation, consult NEMA LSD57-2013.

Air Tight

Housing certified Air Tight as per ASTM E283

California Title 24 JA8 Compliant

No

California Energy Commission (CEC) Status

Lawful for Sales in California

INSTALLATION

Mounting

Recessed

Base Type

Quick Connector or E26 socket

ELECTRICAL

Input Voltage

120/277V

OTHER

Warranty

The RAB 5-year, limited warranty covers light output, driver performance and paint finish. RAB's warranty is subject to all terms and conditions found at rablighting.com/warranty.

DIMENSIONS

FRCANIC4R

FRCANIC4R/E26

Weight: 3.98 lbs

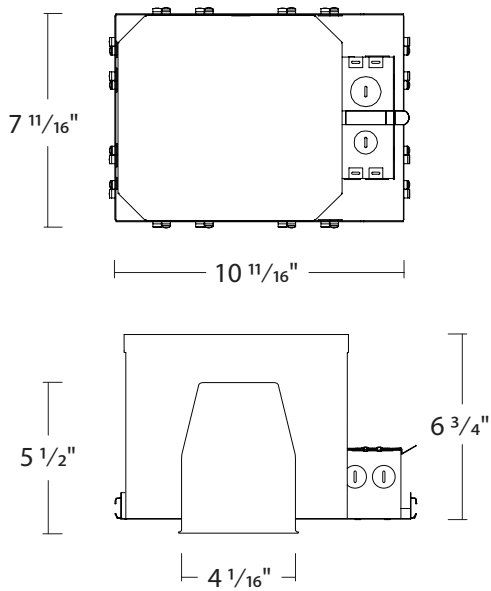

FRCANIC6R

FRCANIC6R/E26

Weight: 3.98 lbs

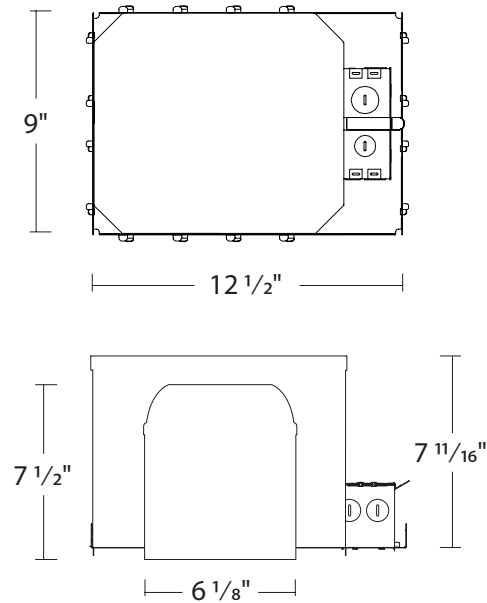

Fire-Rated Housings



ORDERING INFO

Catalog Number	UPC	Case Pack
FRCANIC4R	192552057042	4
FRCANIC4R/E26	192552057059	4
FRCANIC6R	192552057066	4
FRCANIC6R/E26	192552057073	4

ORDERING MATRIX

Family	Type	Voltage	Size	Shape	Connection Type
FRCAN	Blank IC Rated	Blank 120/277V	4 6" 6"	R Round	Blank /E26 Quick Connector Edison