

INSTRUCTIONS

Daisy Chain FA Wafer Downlight Kit



RAB Lighting is committed to creating high-quality, affordable, well-designed and energy-efficient LED lighting and controls that make it easy for electricians to install and end users to save energy. We'd love to hear your comments. Please call the Marketing Department at 888-RAB-1000 or email: marketing@rablighting.com

DAISYKIT4
DAISYKIT4B
DAISYKIT6
DAISYKIT6B



IMPORTANT

READ CAREFULLY BEFORE INSTALLING FIXTURE. RETAIN THESE INSTRUCTIONS FOR FUTURE REFERENCE.

RAB fixture must be wired in accordance with the National Electrical Code and all applicable local codes. Proper grounding is required for safety. THIS PRODUCT MUST BE INSTALLED IN ACCORDANCE WITH THE APPLICABLE INSTALLATION CODE BY A PERSON FAMILIAR WITH THE CONSTRUCTION AND OPERATION OF THE PRODUCT AND THE HAZARDS INVOLVED.

TO PREVENT ELECTRICAL SHOCK, POWER SHOULD BE TURNED OFF AT THE FUSE BOX BEFORE INSTALLATION.

SAFETY WARNINGS:

Read all product labels and directions.

- **WARNING – Risk of fire or electric shock. Install this kit only in the luminaires that have the construction features and dimensions shown in the photographs and/or drawings and where the input rating of the retrofit kit does not exceed the input rating of the luminaire.**
- **Installation should be performed only by a qualified electrician in accordance with the National Electrical Code and relevant local codes. Do not make or alter any open holes in an enclosure of wiring or electrical components during kit installation.**
- **WARNING – To prevent wiring damage or abrasion, do not expose wiring to edges of sheet metal or other sharp objects.**
- **INSTALLATION SHOULD ONLY BE PERFORMED AFTER POWER TO THE FIXTURE HAS BEEN DISCONNECTED.**
- These instructions shall be included on an information sheet packaged with each unit.
- This device complies with Part 15 of the FCC Rules. Operation is subject to the following two conditions:
(1) this device may not cause harmful interference, and (2) this device must accept any interference received, including interference that may cause undesired operation.

WHAT'S IN THE BOX

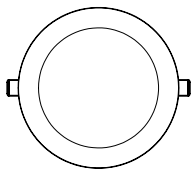

Fixture (6)

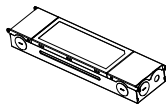

Driver Box (1)



Template (1)

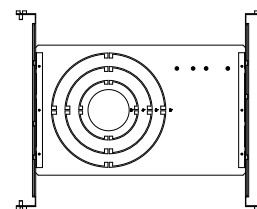

DLPLATE/WFR3468/NB
Mounting plate with nailer bar

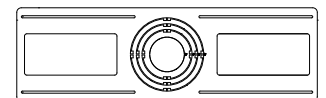

DLPLATE/WFR3456
Mounting plate

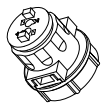

Connector (6)

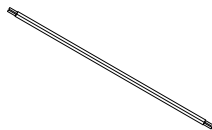

50ft AWG16 Cable (1)

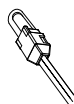

Cable Termination Cap (1)

OPTIONAL ACCESSORIES

TOOLS NEEDED

This Daisy Chain Wafer requires very few tools for installation. A screwdriver and a pair of wirecutters will help to install.

INSTRUCTIONS

Daisy Chain FA Wafer Downlight Kit



RAB Lighting is committed to creating high-quality, affordable, well-designed and energy-efficient LED lighting and controls that make it easy for electricians to install and end users to save energy. We'd love to hear your comments. Please call the Marketing Department at 888-RAB-1000 or email: marketing@rablighting.com

INSTALLATION INSTRUCTIONS

1. Turn power OFF from the electrical panel before installation.
2. Determine how many downlights will be installed with the Power Supply. Carefully measure where each fixture will be installed, use template inside box to cut hole in ceiling. (Fig.1)

Fig: 1

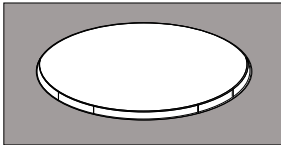

IMPORTANT NOTE:

Maximum connected wafer is 10 pcs (4-inch) and 8 pcs (6-inch).

3. Open the driver box and remove the knockout(s). Insert the electrical supply cable through the knockout and secure with a terminal. Wire driver box (Fig.2), white-white, black - black, green - green/ground.

Fig: 2

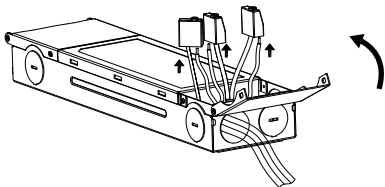

4. Connect the 50ft cable to the low voltage cable, tie a knot during installation to prevent the outside tension from falling off. Wire nut the pink input wire with dim-, the purple input wire with dim+. If the yellow wire is not in use, cap it with wire nut. (Fig.3)

Fig: 3

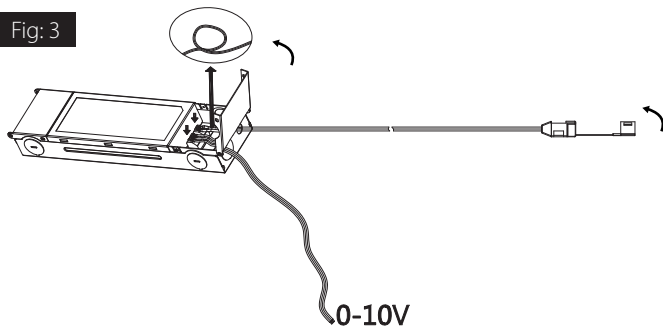

INSTALLATION INSTRUCTIONS (cont'd)

5. Place the Power Supply thru the opening. (Fig.4)

Fig: 4

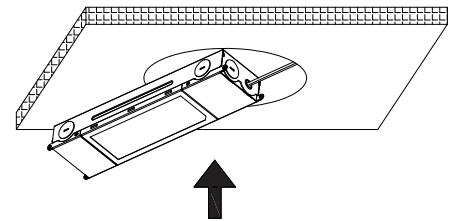

6. Route the low voltage cable to additional fixture locations. Pull enough slack through each hole to make connecting the fixtures easier. (Fig.5)

Fig: 5

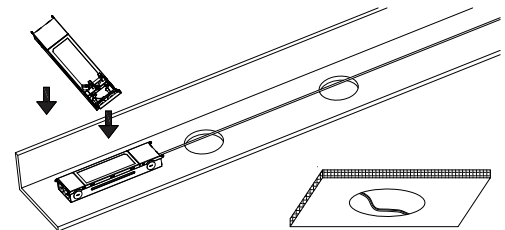

7. Attach the termination cap to the end of the 50ft cable. Use the reusable cable tie to bundle the remaining cable and store it in the ceiling. (Fig.6)

Fig: 6

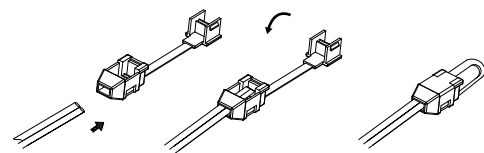

8. Separate connector, cable, and fixture. (Fig.7)

Fig: 7

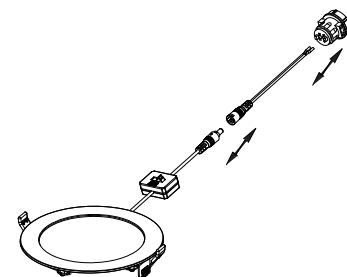

Note: These instructions do not cover all details or variations in equipment nor do they provide for every possible situation during installation, operation or maintenance.

INSTRUCTIONS

Daisy Chain FA Wafer Downlight Kit



RAB Lighting is committed to creating high-quality, affordable, well-designed and energy-efficient LED lighting and controls that make it easy for electricians to install and end users to save energy. We'd love to hear your comments. Please call the Marketing Department at 888-RAB-1000 or email: marketing@rablighting.com

INSTALLATION INSTRUCTIONS (cont'd)

9. Separate the connector by rotating the bottom piece counterclockwise. (Fig.8)

Fig: 8

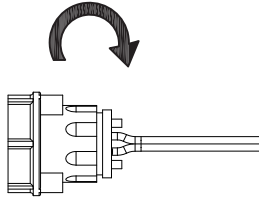

10. Slide either edge of the cable into the slot of the connector's top. (Fig.9)

Fig: 9

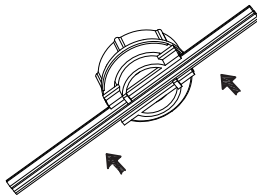

11. Allow the fixture to hang freely, align the metal pin on the bottom piece (attached to the light) with the metal insert in the top. (Fig.10)

Fig: 10

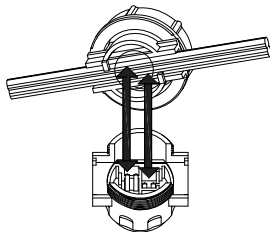

12. Push together and rotate the bottom piece clockwise onto the top, until secure. (Fig.11)

Fig: 11

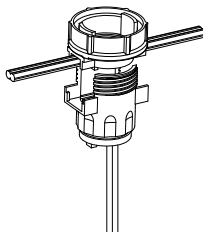

INSTALLATION INSTRUCTIONS (cont'd)

13. Select desired CCT. (Fig.12)

Fig: 12

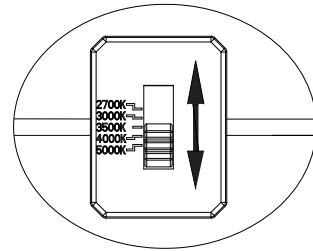

14. Connect the fixture to the connector. (Fig.13)

Fig: 13

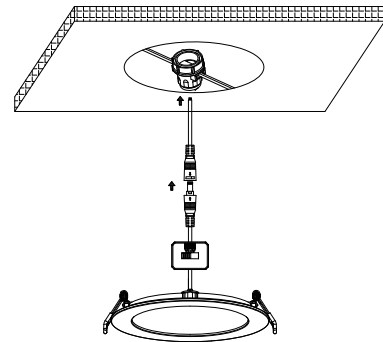

15. Lift both retention tabs upward. Push until the trim sits flush against the ceiling. (Fig.14)

Fig: 14

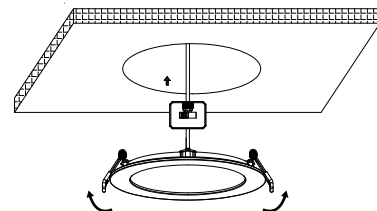

Note: These instructions do not cover all details or variations in equipment nor do they provide for every possible situation during installation, operation or maintenance.