

# INSTALLATION INSTRUCTIONS

## REMOTE TEST SWITCH

### READ AND FOLLOW ALL SAFETY INSTRUCTIONS

**IMPORTANT SAFEGUARDS:** When using electrical equipment, basic safety precautions should always be followed, including the following:

1. Consult local building code for approved wiring and installation.
2. Disconnect AC power before servicing and installation.
3. Do not mount near gas or electric heaters.
4. Do not use outdoors.
5. Do not use this equipment for anything other than its intended use.
6. The use of accessory equipment not recommended by the manufacturer will void product listing and warranty and may cause an unsafe condition.
7. Any service on this equipment should be performed by qualified personnel only.
8. Equipment should be mounted in locations and at heights where it will not be subject to tampering by unauthorized personnel.
9. Cap unused wires with enclosed wire nuts or other approved method.
10. Make sure wire terminations are secure and leads are properly tucked in appropriate wire channels.



### INSTALLATION:

1. Extend a consistent, unswitched AC supply of rated voltage to the Remote Test Switch installation area. Attach AC supply to a standard single-gang electrical box (by others) **Caution: Do not supply AC current until indicated.**
2. The Remote Test Switch option can be used in either 120 or 277VAC applications.
3. Extend a grounded supply circuit from the emergency unit or exit fixture(s) to be controlled to the junction boxes.
4. All wiring connections should be in accordance with NEC and local code requirements. Install fixture(s) to be controlled according to the instructions provided with the exit sign or unit.
5. Wire the Remote Test Switch as follows:  
Connect Remote Test Switch using approved connectors and wiring.  
Refer to Wiring Diagram at right for proper connections.

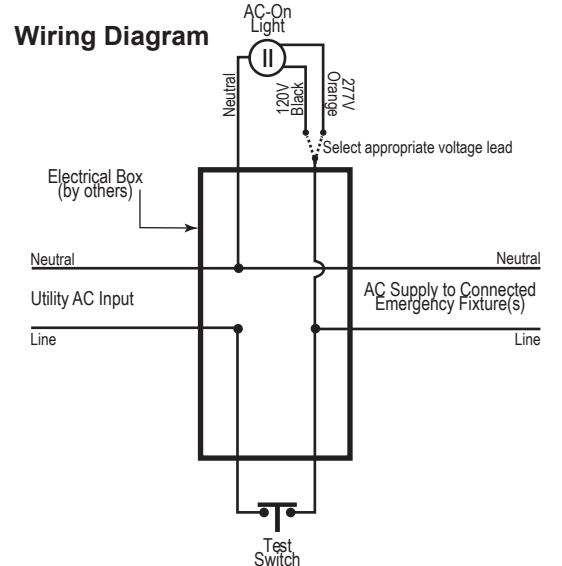

- a) Use the provided wire nut to connect the utility AC input line to one test switch lead.
  - b) Use the provided wire nut to connect the AC On pilot light neutral wire, the utility AC input neutral conductor, and AC supply neutral conductor.
  - c) Use the provided wire nut to connect the appropriate voltage lead from the AC On pilot light (120V-Black, 277V- Orange) and the free test switch lead to the AC supply line conductor.
  - d) Connect ground wires in accordance with local codes.
6. Use the two #6-32 screws provided to mount the Remote Test Switch cover plate to the electrical box.
  7. Energize the Remote Test Switch to the utility AC input circuit. All connected fixtures should operate normally in the AC mode.

### OPERATION:

To test the Remote Test Switch (RTS):

1. Press the RTS module's test switch. All the connected emergency fixtures should now operate in emergency mode and the AC On pilot light will turn off.
2. When the test switch is released, all connected emergency fixtures should resume normal AC operation mode and the AC On pilot light will light.

**SAVE THESE INSTRUCTIONS!**