

INSTRUCTIONS

EM EMERGENCY LIGHTING INSTALLATION

RAB®

RAB Lighting is committed to creating high-quality, affordable, well-designed and energy-efficient LED lighting and controls that make it easy for electricians to install and end users to save energy. We'd love to hear your comments. Please call the Marketing Department at 888-RAB-1000 or email: marketing@rablighting.com

**** DON'T TOSS IT—RECYCLE IT! MAKE THE SUSTAINABLE CHOICE BY RECYCLING THIS FIXTURE AT END OF LIFE WITH A LICENSED RECYCLING PROVIDER. ****



EM
EM-R



EM-B
EM-R-B

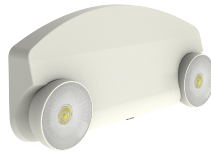

EM34
EM34-R

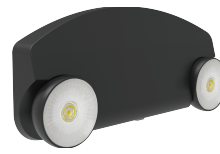

EM34-B
EM34-R-B



EMR
EMR-R

IMPORTANT

READ CAREFULLY BEFORE INSTALLING FIXTURE. RETAIN THESE INSTRUCTIONS FOR FUTURE REFERENCE.

RAB fixtures must be wired in accordance with the National Electrical Code and all applicable local codes. Proper grounding is required for safety. THIS PRODUCT MUST BE INSTALLED IN ACCORDANCE WITH THE APPLICABLE INSTALLATION CODE BY A PERSON FAMILIAR WITH THE CONSTRUCTION AND OPERATION OF THE PRODUCT AND THE HAZARDS INVOLVED.

IMPORTANT:

Let the battery charge up for at least 24 hours. Then normal operation of this unit should take effect. To check, press the "TEST" button. The LED lamps on the unit should turn ON. During an electrical power failure, the led lamps will automatically come on for a minimum of 90 minutes. In accordance with NFPA 101, your emergency lighting system must be tested monthly for a minimum of 30 seconds and annually for 90 minutes. Refer to your local codes for any additional requirements that may apply.

IMPORTANT SAFEGUARDS:

When using electrical equipment, basic safety precautions should always be followed including the following:

READ AND FOLLOW ALL SAFETY INSTRUCTIONS

1. Do not use outdoors.
2. Equipment should be mounted in locations and at heights where it will not be subject to tampering by unauthorized personnel.
3. Do not mount near gas or electric heaters.
4. The use of accessory equipment not recommended by the manufacturer may cause an unsafe condition.
5. Do not use this equipment for anything other than its intended use.
6. Servicing of this equipment should be performed by qualified personnel.
7. Disconnect AC power before servicing.

J-BOX MOUNTING INSTALLATION

1. Feed fixture leads through the back plate and connect to AC power supply (Fig. 1).
2. Attach back plate to J-Box and secure with screws.
3. Complete the **battery connection**. (Fig. 2)(EM34, EM34-R, EM34-B, EM34-R-B, EMR, EMR-R are the same operation)
4. Align snaps and push housing directly onto the back plate (Fig. 3)(EM34, EM34-R, EM34-B, EM34-R-B, EMR, EMR-R are the same operation).
Apply continuous AC power and press "TEST" button to check light.

Fig: 1

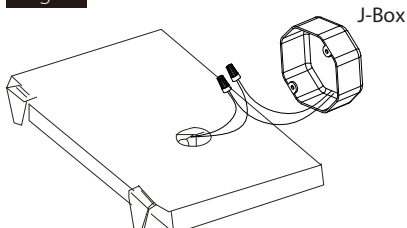

Fig: 2

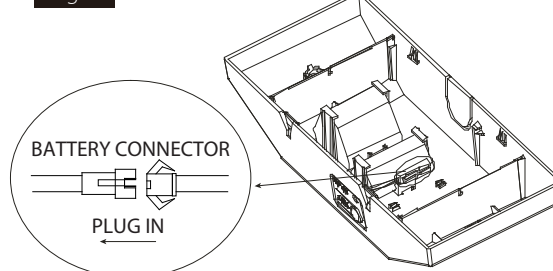
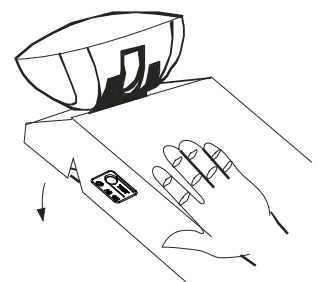

Fig: 3



INSTRUCTIONS

EM EMERGENCY LIGHTING INSTALLATION



RAB Lighting is committed to creating high-quality, affordable, well-designed and energy-efficient LED lighting and controls that make it easy for electricians to install and end users to save energy. We'd love to hear your comments. Please call the Marketing Department at 888-RAB-1000 or email: marketing@rablighting.com

**** DON'T TOSS IT—RECYCLE IT! MAKE THE SUSTAINABLE CHOICE BY RECYCLING THIS FIXTURE AT END OF LIFE WITH A LICENSED RECYCLING PROVIDER. ****

CONDUIT INSTALLATION

1. Secure back plate to wall surface . Route wires through hole in conduit flange and make conduit connection.
2. Complete the **battery connection** (Fig. 2)(EM34, EM34-R, EM34-B, EM34-R-B, EMR, EMR-R are the same operation).
3. Align snaps and push housing directly onto the back plate (Fig. 3)(EM34, EM34-R, EM34-B, EM34-R-B, EMR, EMR-R are the same operation). Apply continuous AC power and press "TEST" button to check light.

Fig: 4

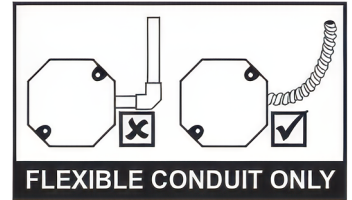

OPERATION

1. During an electrical power failure, the LED lamps will automatically come on for a minimum of 90 minutes.
2. To test, depress the "TEST" switch. The emergency LED lamps will illuminate. When the switch is released, the lamps will go off.

WIRING DIAGRAMS

NOTE: Use 18-22 AWG stranded wire to connect remote lamp heads.

REMOTE CAPABLE

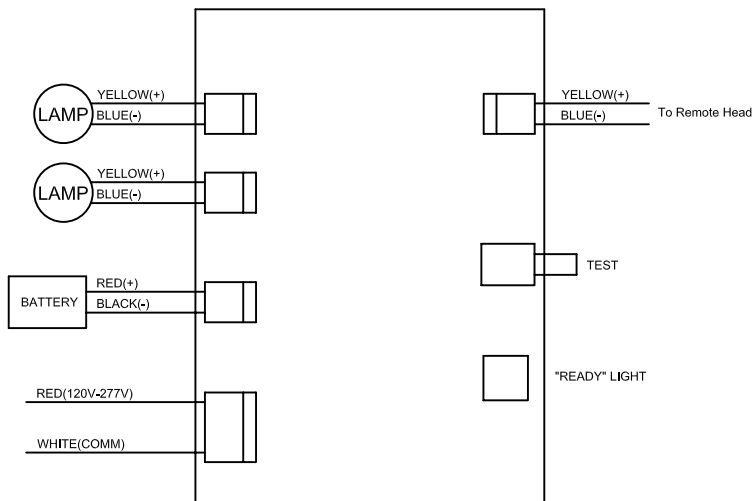

REGULAR

