

INSTRUCTIONS

GUS® JR WRAP INSTALLATION

RAB®

RAB Lighting is committed to creating high-quality, affordable, well-designed and energy-efficient LED lighting and controls that make it easy for electricians to install and end users to save energy. We'd love to hear your comments. Please call the Marketing Department at 888-RAB-1000 or email: marketing@rablighting.com



GUSJR- 2FT

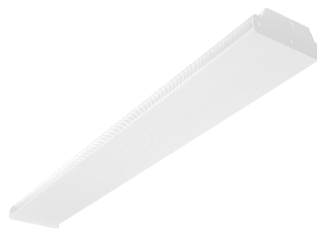

GUSJR - 4FT

IMPORTANT

READ CAREFULLY BEFORE INSTALLING FIXTURE. RETAIN THESE INSTRUCTIONS FOR FUTURE REFERENCE.

RAB fixtures must be wired in accordance with the National Electrical Code and all applicable local codes. Proper grounding is required for safety. THIS PRODUCT MUST BE INSTALLED IN ACCORDANCE WITH THE APPLICABLE INSTALLATION CODE BY A PERSON FAMILIAR WITH THE CONSTRUCTION AND OPERATION OF THE PRODUCT AND THE HAZARDS INVOLVED.

WARNING: Make certain power is OFF before installing or maintaining fixture. No user serviceable parts inside.

SURFACE MOUNTING

The fixture is suitable for indoor applications for ceiling or wall mounting, as follows:

1. Carefully snap out **Lens** one side at a time from **Housing**.
2. Rotate the **Fasteners (4)** 90 degrees and remove them from **LED Tray Kit**. Unclip pre-installed **Tether Cables (2)** as shown in **Fig. 1** to separate **LED Tray Kit** from the **Housing**.
3. Pull supply wires from Junction Box (*not supplied*) through **Center Access Hole** of **Housing** as shown in **Fig. 1**. Use appropriate UL-rated wire connectors as required by code to make electrical splices to fixture leads.
4. Secure **Housing** to junction box or mount **Housing** directly to a sturdy surface by using the **Drill Locations (4 holes for 2 ft & 4 ft fixture)** fixture. Use the appropriate mounting hardware for the mounting surface.
5. Once connection is made reinstall the **Tether Cable (2)** to **LED Tray Kit** and plug in the **Quick Connector**. Push the **LED Tray Kit** into the **Housing** and rotate the **Fasteners (4)** to secure. Ensure that the wires are not pinched between **Housing** and **LED Tray Kit**.
6. Replace **Lens**. Hook **Lens** to one side of **Housing** and snap **Lens** into place as shown in **Fig. 2**.

WARNING: To prevent wiring damage or abrasion, do not expose wiring to edges of sharp objects.

Fig: 1

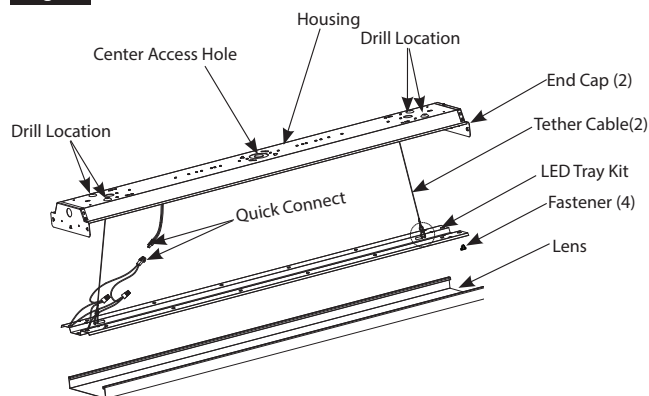
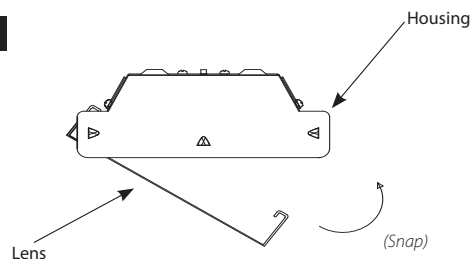

Fig: 2



INSTRUCTIONS

GUS® JR WRAP INSTALLATION



RAB Lighting is committed to creating high-quality, affordable, well-designed and energy-efficient LED lighting and controls that make it easy for electricians to install and end users to save energy. We'd love to hear your comments. Please call the Marketing Department at 888-RAB-1000 or email: marketing@rablighting.com

V-HOOK MOUNTING

The fixture can be mounted using V-hook
(ordered separately as VHOOKGUSJR).

1. Mount **V-hook** to the housing as shown in **Fig. 3**. Use the appropriate mounting hardware for the mounting surface
2. For electrical wiring, snap out the **Lens and LED Tray Kit** as shown in **Fig.1**.
3. Pull supply wires in fixture through **Central Access Hole**. Use appropriate UL-rated wire connectors as required by code to make electrical splices to fixture leads.

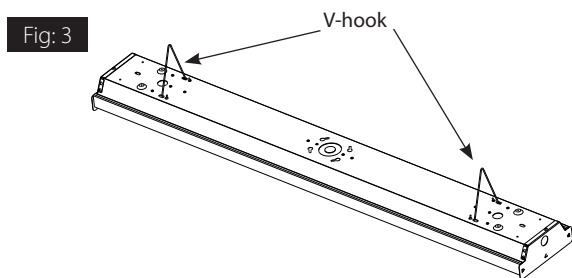

ROW MOUNTING AND THROUGH WIRING

1. Line up the fixtures end to end and secure together as shown in Fig. 4 using **Screws (2)** provided.
2. Follow directions on Page 1 to secure housings to mounting surface. If necessary, feed wires through from one fixture to the other.

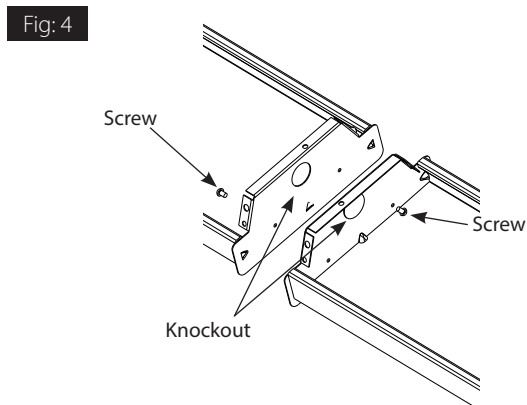

0-10V DIMMABLE WIRING

Universal voltage driver permits operation at 120V thru 277V, 50 or 60 Hz. For 0-10V Dimming, follow the wiring directions in **Fig. 5**.

1. Connect the **black** fixture lead to the **LINE** supply lead
2. Connect the **white** fixture lead to the **COMMON** supply lead.
3. Connect the **GROUND** wire from fixture to **supply ground**.
4. Connect the **purple** fixture lead to the **(V+) DIM** lead.
5. Connect the **pink (or gray)** fixture lead to the **(V-) DIM** lead.
6. Cap the **yellow** fixture lead, if present. **Do NOT** connect.

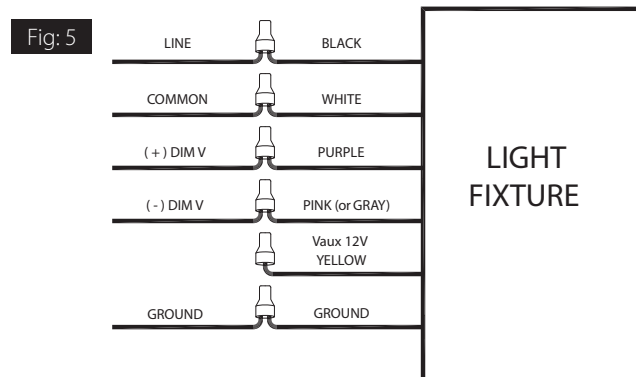

CLEANING & MAINTENANCE

CAUTION: Be sure fixture temperature is cool enough to touch.
Do not clean or maintain while fixture is energized.

1. Clean acrylic lens with non-abrasive cleaning solution.
2. Do not open the fixture to clean the LEDs. Do not touch the LEDs.

TROUBLESHOOTING

1. Check that the line voltage at the fixture is correct. Refer to wiring directions.
2. Be sure the fixture is grounded properly.

Note: These instructions do not cover all details or variations in equipment nor do they provide for every possible situation during installation operation or maintenance.

INSTRUCTIONS

GUS® JR WRAP INSTALLATION



RAB Lighting is committed to creating high-quality, affordable, well-designed and energy-efficient LED lighting and controls that make it easy for electricians to install and end users to save energy. We'd love to hear your comments. Please call the Marketing Department at 888-RAB-1000 or email: marketing@rablighting.com

BATTERY BACKUP MODELS

WIRING

CAUTION: FOR BATTERY BACKUP FIXTURE.

Voltage can be present in **BATTERY**. To prevent high voltage from being present on output leads, Inverter connector must be open. Do not join **BATTERY** connector until installation is complete and AC power is supplied to the emergency driver (Fig. 6).

NOTE: Make sure that the necessary branch circuit wiring is available. An **UNSWITCHED AC** source of power is required. The emergency driver must be fed from the same branch circuit as the LED driver.

CAUTION: Do not use any supply voltage other than 120-277V 50/60 HZ.

1. Connect **UNSWITCHED HOT** fixture lead to **HOT AC** supply line.
2. If using an **UNSWITCHED** circuit, connect **UNSWITCHED** and **SWITCHED** lines together.
3. If using a **SWITCHED** circuit, connect **SWITCHED HOT AC fixture** lead to the external.
4. Connect the **pink (or gray)** fixture lead to the (V-) **DIM** lead.
5. For 0-10V Dimming, connect **DIM (+)** and **DIM (-)** lead to the supply ground. Do not connect **GROUND** to the output leads.
6. All unused leads must be capped and insulated.
7. After installation is complete, supply **AC power** to the fixture and connect the **BATTERY**.
8. When power is on, the fixture should be on and the **Charging Indicator Light** should illuminate to indicate the battery is charging.
9. Once the **BATTERY** has charged for at least one hour, a short duration test may be performed by pressing the test button.
10. After the battery has charged for 24 hours, a long duration test can be performed by shutting power to the fixture.

Fig. 6

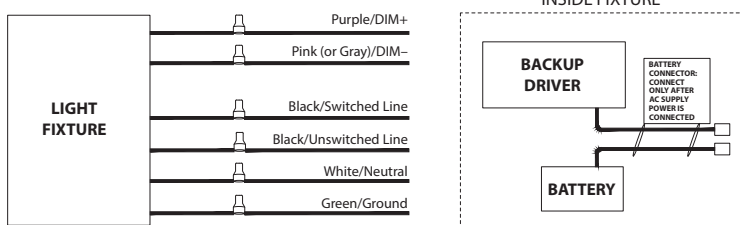

OPERATION

1. When AC power is applied, the charging indicator light is illuminated, indicating that the **BATTERY** is being charged.
Note: The charging indicator light and test switch are located on the LED tray below the lens.
2. When power fails, the standby power automatically switches to backup mode at reduced power, resulting in lower illumination. The emergency driver supplies power in standby mode for a minimum of 90 minutes.
3. When AC power is restored, the emergency driver automatically returns to charging mode.

MAINTENANCE

Although no routine maintenance is required to keep the emergency driver functional, it should be checked periodically to ensure that it is working. The following schedule is recommended:

1. Visually inspect the **Charging Indicator Light** monthly. It should be illuminated.
2. Test the emergency operation of the fixture at 30-day intervals for a minimum of 30 seconds.
3. Conduct a 90-minute discharge test once a year. Fixture would operate at reduced illumination for a minimum of 90 minutes.

TROUBLESHOOTING

1. Is the fixture grounded properly?
2. If the charging indicator light does not illuminate after pressing the test button, check if battery is connected properly.

Note: These instructions do not cover all details or variations in equipment nor do they provide for every possible situation during installation, operation or maintenance.



© 2021 RAB LIGHTING Inc.
GUSJR-IN-1021
73616-RAB

Easy Answers

rablighting.com
Visit our website for product info

Tech Help Line
Call our experts: 888 722-1000

e-mail
Answered promptly - sales@rablighting.com

Free Lighting Layouts
Answered online or by request

RAB WARRANTY: RAB's warranty is subject to all terms and conditions found at rablighting.com/warranty.