

Welcome



Lightcloud™

Controller

LCCONTROL20/D10

WE'RE HERE TO HELP:

1 (844) LIGHTCLOUD

1 (844) 544-4825

support@lightcloud.com

Hello

Lightcloud is a wireless
lighting control service.

The Lightcloud Controller
is a remotely controlled
switch and 0-10V
dimming device.

Product Features

Wireless Control & Configuration

Switching up to 20A

0-10V Dimming

Power Monitoring

Patent Pending

Contents

Lightcloud Controller

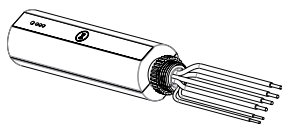

NPT Nut



O-ring



Wire Nuts



Instruction Manual

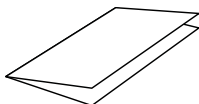

Specifications

PART NUMBER

LCCONTROL20/D10

INPUT

120-277VAC, 50/60Hz
<2W (Standby - 4W (Active))

MAXIMUM SWITCHED LOAD RATINGS

For Control of Magnetic, Electronic Ballast or LED
277VAC: 20A Magnetic/Resistive
240VAC: 5A Tungsten/Electronic, 20A FLA/
60 LRA, 2HP
120VAC: 15A Tungsten, 1HP

OPERATING TEMPERATURE

-40°C to +40°C

OVERALL DIMENSIONS

1.55" diameter, 5.75" length
1/2" NPT Mount, Male
16AWG pigtails

WIRELESS RANGE

Line-of-Sight: 1000 feet
Obstructions: 100 feet

Warranty is active as long as service plan is active
Class 2
IP66 Rated
Indoor and Outdoor Rated
Wet and Damp Location
Plenum Rated

What You Need



Lightcloud Gateway

A Lightcloud installation requires at least one Lightcloud Gateway to manage your devices.

WE'RE HERE TO HELP:

1 (844) LIGHTCLOUD

or 1 (844) 544-4825

support@lightcloud.com

Wiring

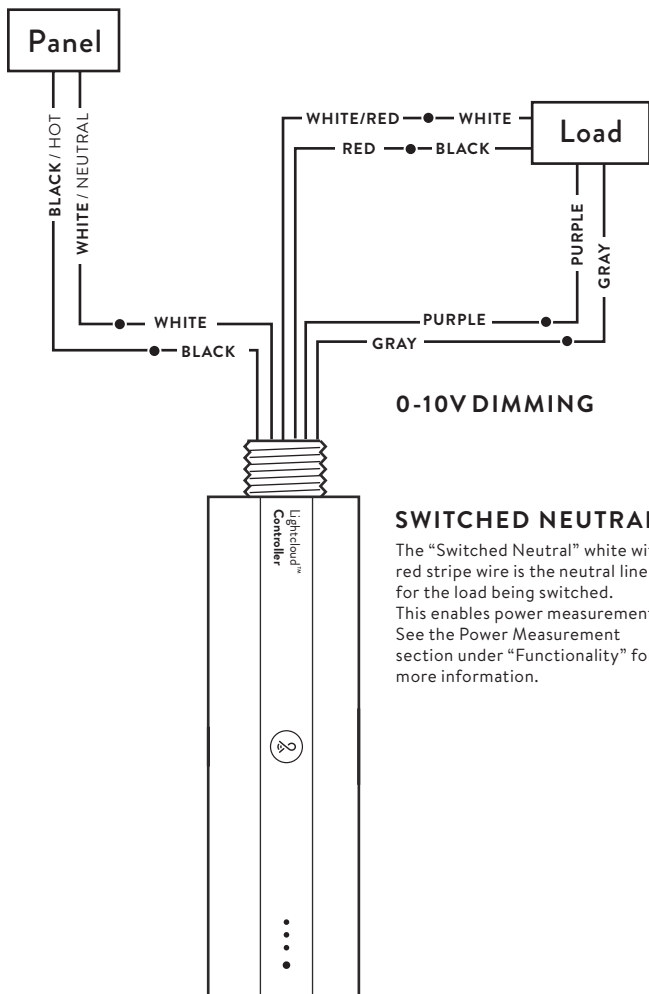

0-10V DIMMING

SWITCHED NEUTRAL

The "Switched Neutral" white with red stripe wire is the neutral line for the load being switched. This enables power measurement. See the Power Measurement section under "Functionality" for more information.

Setup & Installation

1 Turn off power



WARNING

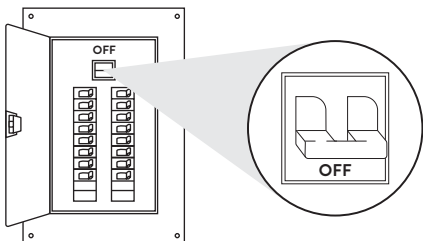

1a Find a Suitable Location

Use these guidelines when installing devices:

- If there is a clear line of sight between two Lightcloud devices, they can be placed up to 1000 feet apart.
- If the two devices are separated by ordinary drywall construction, try to keep them within 100 ft. of each other.
- Brick, concrete and steel construction may require additional Lightcloud devices to go around the obstruction.

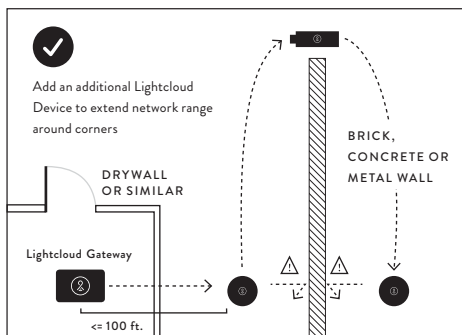

Setup & Installation (cont'd)

2 Install your Lightcloud Controller

2a Install at a Junction Box (Indoor/Outdoor)

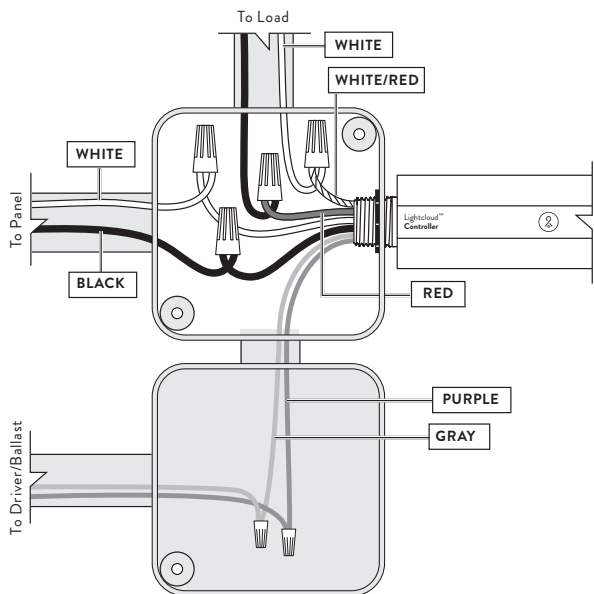

0-10V DIMMING

0-10V is a common method of low-voltage control of dimmable drivers and ballasts. **Purple:** 0-10V positive | **Gray:** 0-10V common

NOTE: The National Electrical Code requires that low-voltage wiring used in the same enclosure as high-voltage wiring have an equal or better insulation rating. You may need to complete your low-voltage wiring in another enclosure or use a partition.

2b At Lighting Panel or Trough

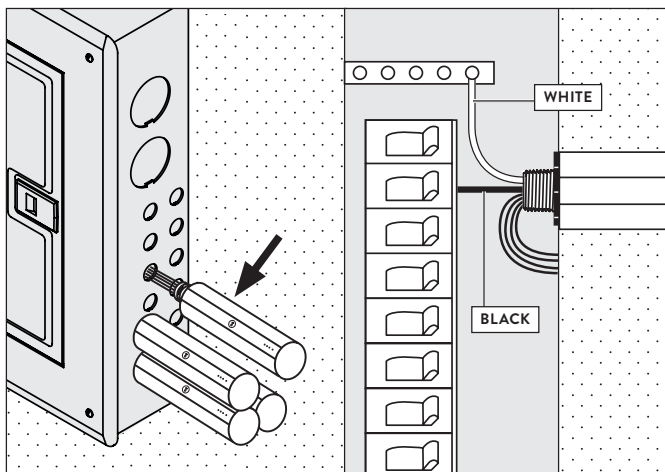

Space and code allowing, you may install Lightcloud devices directly in your breaker box or lighting panel. Alternatively, break out lighting circuits and install Lightcloud devices in a separate trough.

Setup & Installation (cont'd)

③ Labeling your device

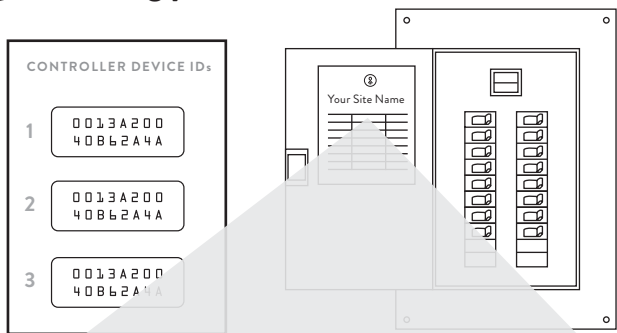

	DEVICE ID	ZONE NAME	PANEL/ CIRCUIT #	DIMMING
1	0013A200 40B62A4A	Front Desk	2	✓

For setup and maintenance, we provide two Lightcloud Device Tables with the Gateway: one that you can attach to your panel and one to hand off to a building manager. Attach the Device Identification stickers included with each device to a row, then write in additional information, such as Zone name, Panel/Circuit Number, and whether or not a zone uses dimming.

④ Power up

To add new devices to your Lightcloud network, call RAB at 1 (844) LIGHTCLOUD, or email us at support@lightcloud.com.

5 Confirm Device Connectivity

Confirm Status Indicator is Solid Green (see details below)

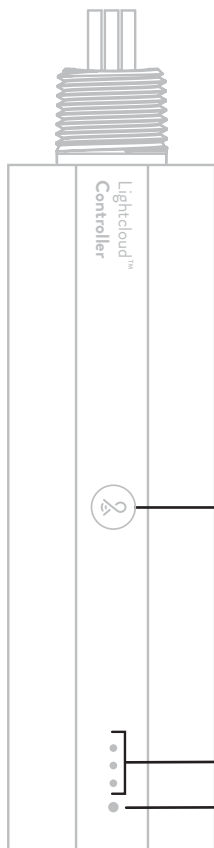

DEVICE IDENTIFICATION BUTTON

- Illuminated when device is powered
- Press once to highlight this device in the Lightcloud Application
- Press twice to toggle circuit on and off
- Press twice and hold to set dim level
- Press and hold for 10 seconds to remove this device from a Lightcloud network
- Blinks when device is indicated from the Lightcloud Application

SIGNAL INDICATOR

Illuminates when the device receives a message and indicates the strength of the signal.

3 - Best signal

2 - Acceptable signal

1 - Unacceptable signal

Consult the "Finding a Location" section for more information

STATUS INDICATOR

Solid GREEN when connected to your Lightcloud network. Blinking RED when not connected. The device will automatically continue trying to connect to a network in Setup Mode.

6 Commission your devices

Log on to www.lightcloud.com or call 1 (844) LIGHTCLOUD

Functionality

Configuration

All configuration of Lightcloud products may be performed using the Lightcloud web or mobile application, or by calling RAB.

WE'RE HERE TO HELP:

1 (844) LIGHTCLOUD

or 1 (844) 544-4825

support@lightcloud.com

Operating Modes

CONTROLLER Provides switching and dimming for a single zone

TRIGGER Detect when an attached circuit is open or closed. For example, you could attach the Controller in Trigger mode to an existing occupancy sensor to allow your Lightcloud system to react to the sensor.

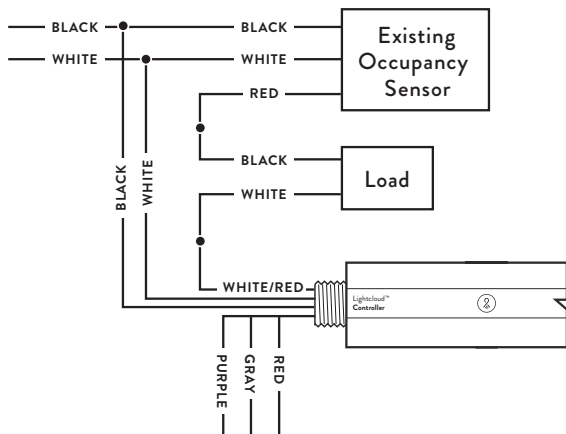

REPEATER: Disables zone control and power measurement, and extends the range of your network.

POWER MEASUREMENT: The Lightcloud Controller is capable of measuring the power usage of the attached circuit. In order to utilize this function, the neutral wire of the load must be connected to the white-red sense wire. If the Switched Neutral line cannot be used, it should be tied to the regular neutral wires (i.e. all neutral wires joined).

POWER LOSS DETECTION: If mains power to the Controller is lost, the device will detect this and alert the Lightcloud application.

EMERGENCY DEFAULT: If communication is lost, the Controller may optionally fall back to a specific state, such as turning the attached circuit on.



**Any wires not in use must be capped off
or otherwise insulated.**

FCC Information:

This device complies with Part 15 of the FCC Rules. Operation is subject to the following two conditions:

- 1. This device may not cause harmful interference, and*
- 2. This device must accept any interference received, including interference that may cause undesired operation.*

Note: This device has been tested and found to comply with the limits for Class B digital devices pursuant to Part 15 Subpart B, of the FCC rules. These limits are designed to provide reasonable protection against harmful interference in a residential environment. This equipment generates, uses, and can radiate radio frequency energy, and if not installed and used in accordance with the instruction manual, may cause harmful interference to radio communications. However, there is no guarantee that interference will not occur in a particular installation. If this equipment does cause harmful interference to radio or television reception, which can be determined by turning the equipment off and on, the user is encouraged to try and correct the interference by one or more of the following measures:

- Reorient or relocate the receiving antenna.*
- Increase the separation between the equipment and receiver.*
- Connect the equipment into an outlet on a circuit different from that to which the receiver is connected.*
- Consult the dealer or an experienced radio/TV technician for help.*

To comply with the FCC's RF exposure limits for general population / uncontrolled exposure, this transmitter must be installed to provide a separation distance of at least 20 cm from all persons and must not be co-located or operating in conjunction with any other antenna or transmitter.

CAUTION: Changes or modifications to this equipment not expressly approved by RAB Lighting may void the user's authority to operate this equipment.



Lightcloud is a commercial wireless lighting control system & service. It's powerful and flexible, yet easy to use and install. Learn more at lightcloud.com

1 (844) LIGHTCLOUD

1 (844) 544-4825

support@lightcloud.com

RAB[®]

Custom manufactured in China

© RAB Lighting, Inc

170 Ludlow Avenue Northvale, NJ 07647



Lightcloud Controller Switch

Lightcloud Controller used to switch a load without dimming.

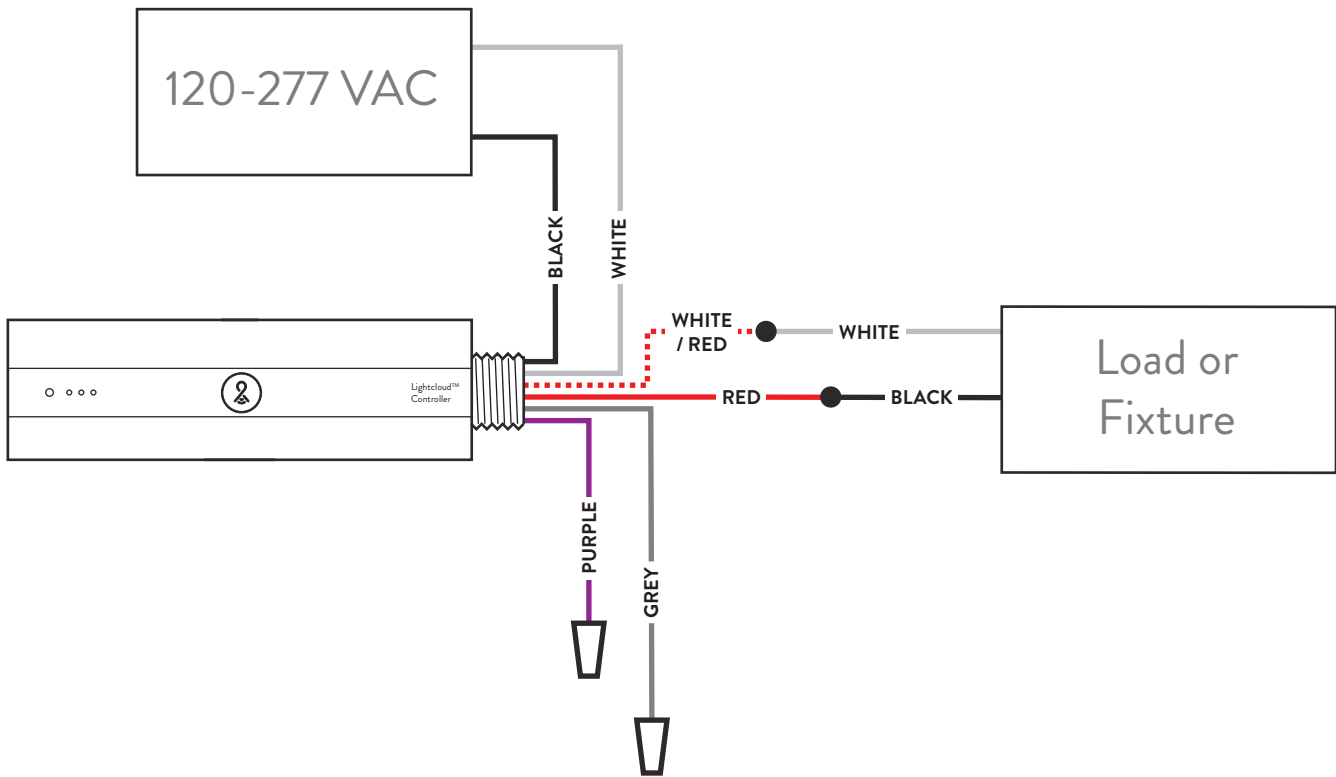

Input: 120-277VAC, 50/60Hz

Switching Capacity (Magnetic, Electronic Ballast or LED)

15.5A (120-277VAC)

277VAC: 20A Magnetic/Resistive

240VAC: 5A Tungsten/Electronic, 20A FLA/60 LRA, 2HP

120VAC: 15A Tungsten, 1HP

Switched Neutral: The “Switched Neutral” white with red stripe wire is the neutral line for the load being switched. This enables power measurement.



Any wires not in use must be capped off or otherwise insulated.
This product should only be installed by a qualified electrician and in compliance with local and national electrical codes.

RAB

Controls



Lightcloud Controller 0-10V Dimming

Lightcloud Controller used to switch a load with 0-10V dimming.

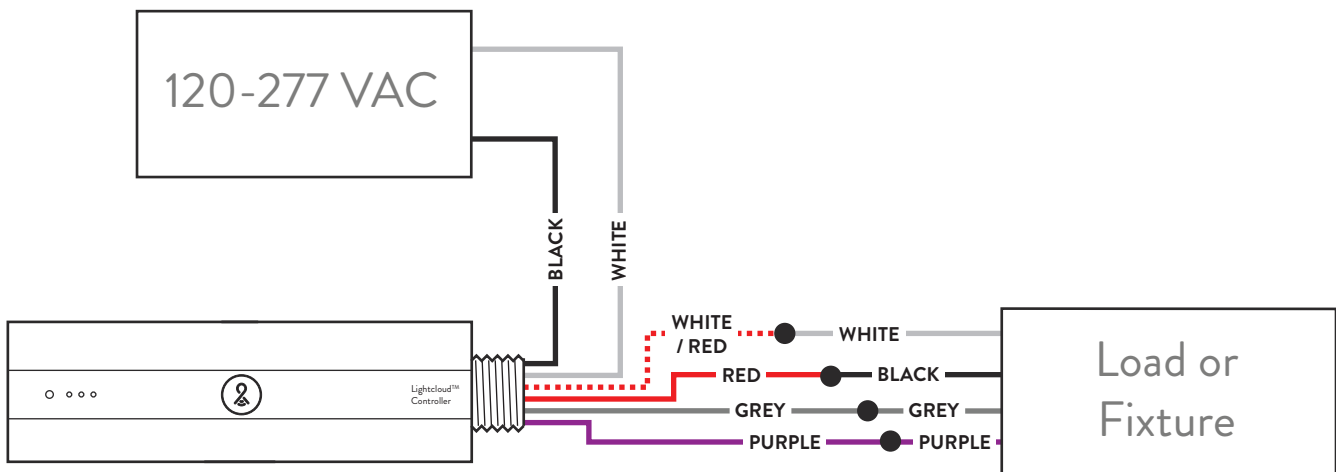

Input: 120-277VAC, 50/60Hz

Purple: 0-10V positive

Grey: 0-10V common

Switching Capacity (Magnetic, Electronic Ballast or LED)

15.5A (120-277VAC)

277VAC: 20A Magnetic/Resistive

240VAC: 5A Tungsten/Electronic, 20A FLA/60 LRA, 2HP

120VAC: 15A Tungsten, 1HP

Switched Neutral: The “Switched Neutral” white with red stripe wire is the neutral line for the load being switched. This enables power measurement.

Note: The National Electrical Code requires that low-voltage wiring use in the same enclosure as high-voltage wiring have an equal or better insulation rating. You may need to complete your low-voltage wiring in another enclosure or use a partition.



Any wires not in use must be capped off or otherwise insulated.
This product should only be installed by a qualified electrician and in compliance with local and national electrical codes.

RAB

Controls



Lightcloud Controller Repeater

Lightcloud Controller used to repeat Lightcloud mesh network signal without controlling a load.

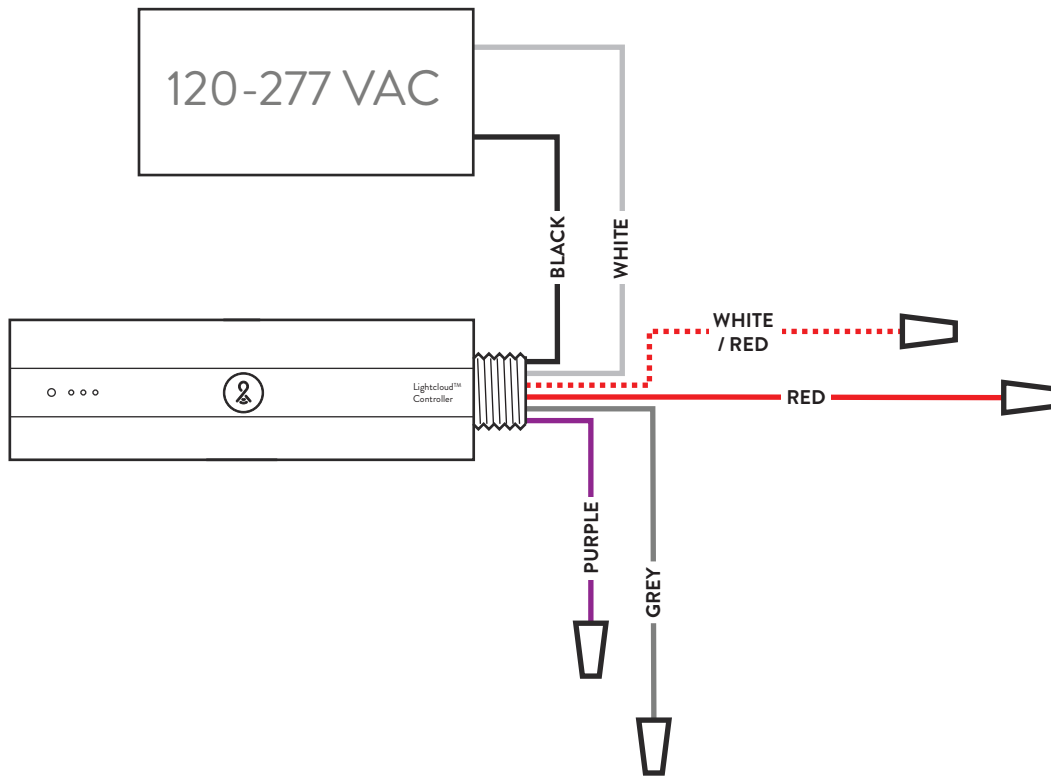

Input: 120-277VAC, 50/60Hz



Any wires not in use must be capped off or otherwise insulated.
This product should only be installed by a qualified electrician and in compliance with local and national electrical codes.

RAB

Controls



Lightcloud Advanced Trigger Wiring

Lightcloud Controllers can receive inputs or triggers from 3rd party switching devices such as outdoor motion or light sensors.

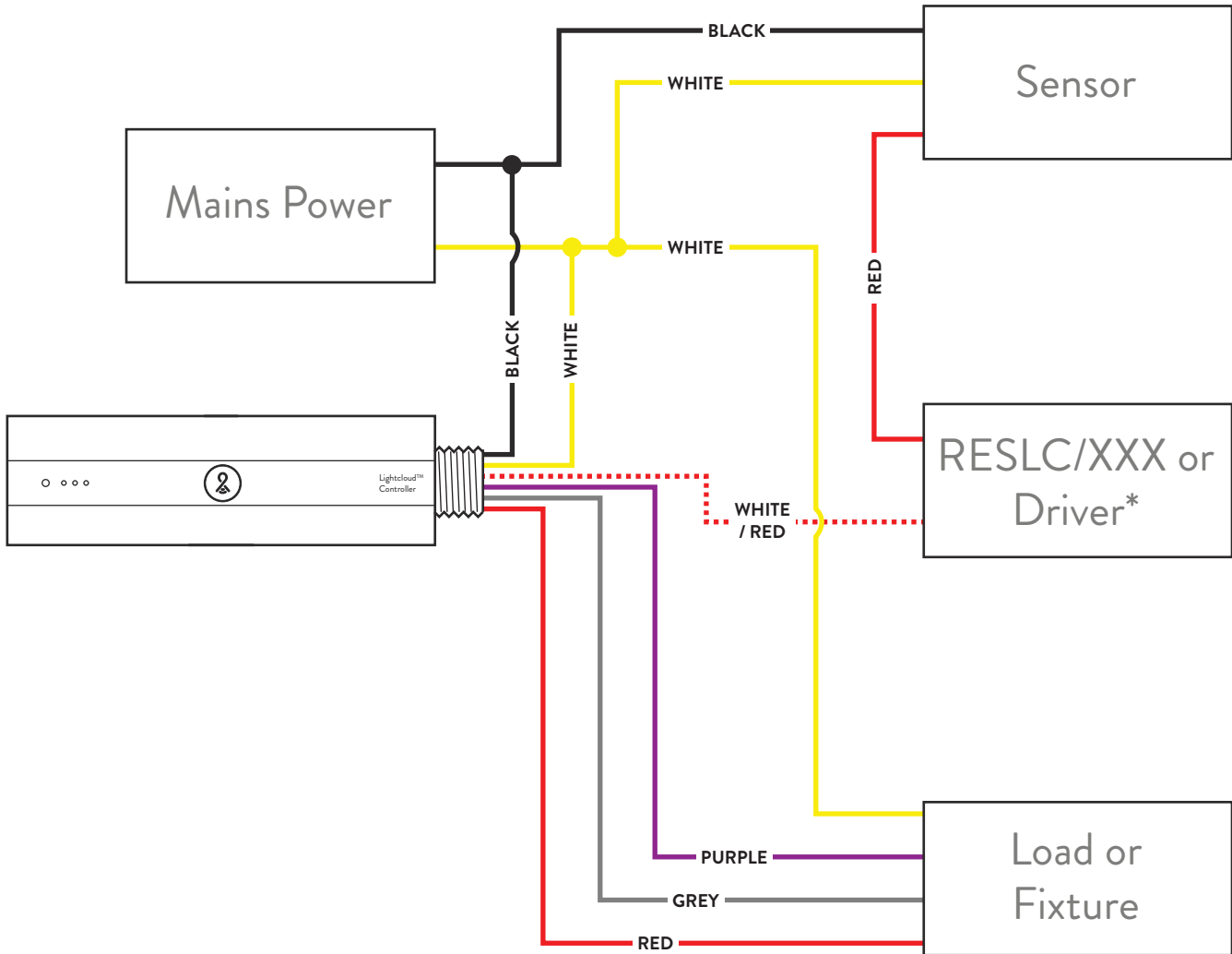

Sample Occupancy Sensor
RAB Stealth STL200



Notes: A resistor or second fixture driver must be used between the Controller and Sensor. RESLC/120 for 120VAC applications or RESLC/277 for 277VAC application. The driver must be greater than 10mA.



Any wires not in use must be capped off or otherwise insulated. This product should only be installed by a qualified electrician and in compliance with local and national electrical codes.

RAB

Controls



Lightcloud Emergency Lighting

Lightcloud Controllers can be used to control Emergency Lighting fed with “Always ON” Emergency Power. Upon loss of power, Emergency lighting will fail to “Full ON” light output.

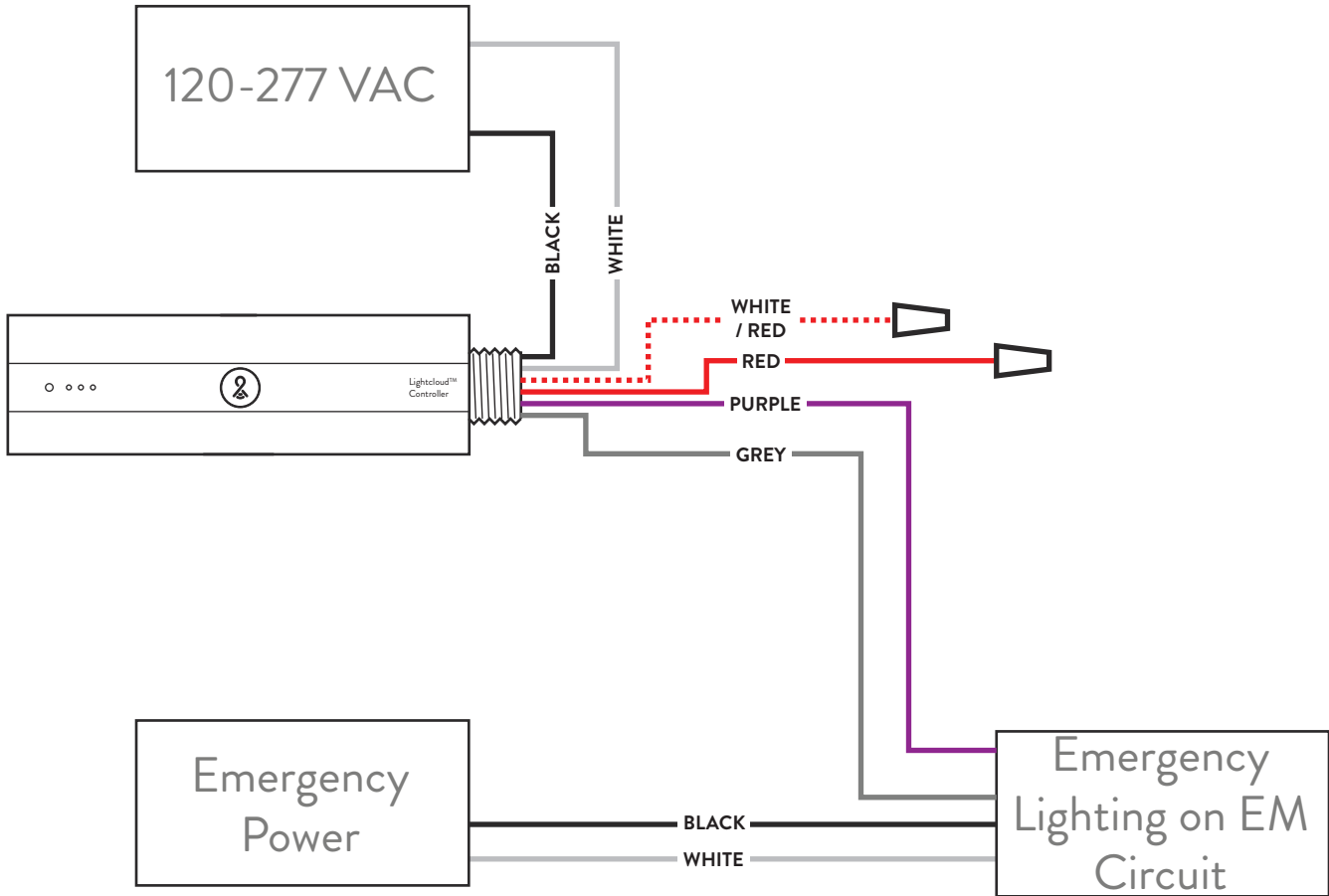

Notes: In spaces where there is only one luminaire, and it is connected to emergency power, the Controller will need to be connected to a Normal Power Circuit for proper operation. Emergency fixtures with on-board battery backup don't require special wiring.



Any wires not in use must be capped off or otherwise insulated. This product should only be installed by a qualified electrician and in compliance with local and national electrical codes.

RAB

Controls



Lightcloud Emergency and Normal Lighting

Lightcloud Controllers can be used to control Emergency Lighting fed with “Always ON” Emergency Power. Upon loss of power, Emergency lighting will fail to “Full ON” light output.

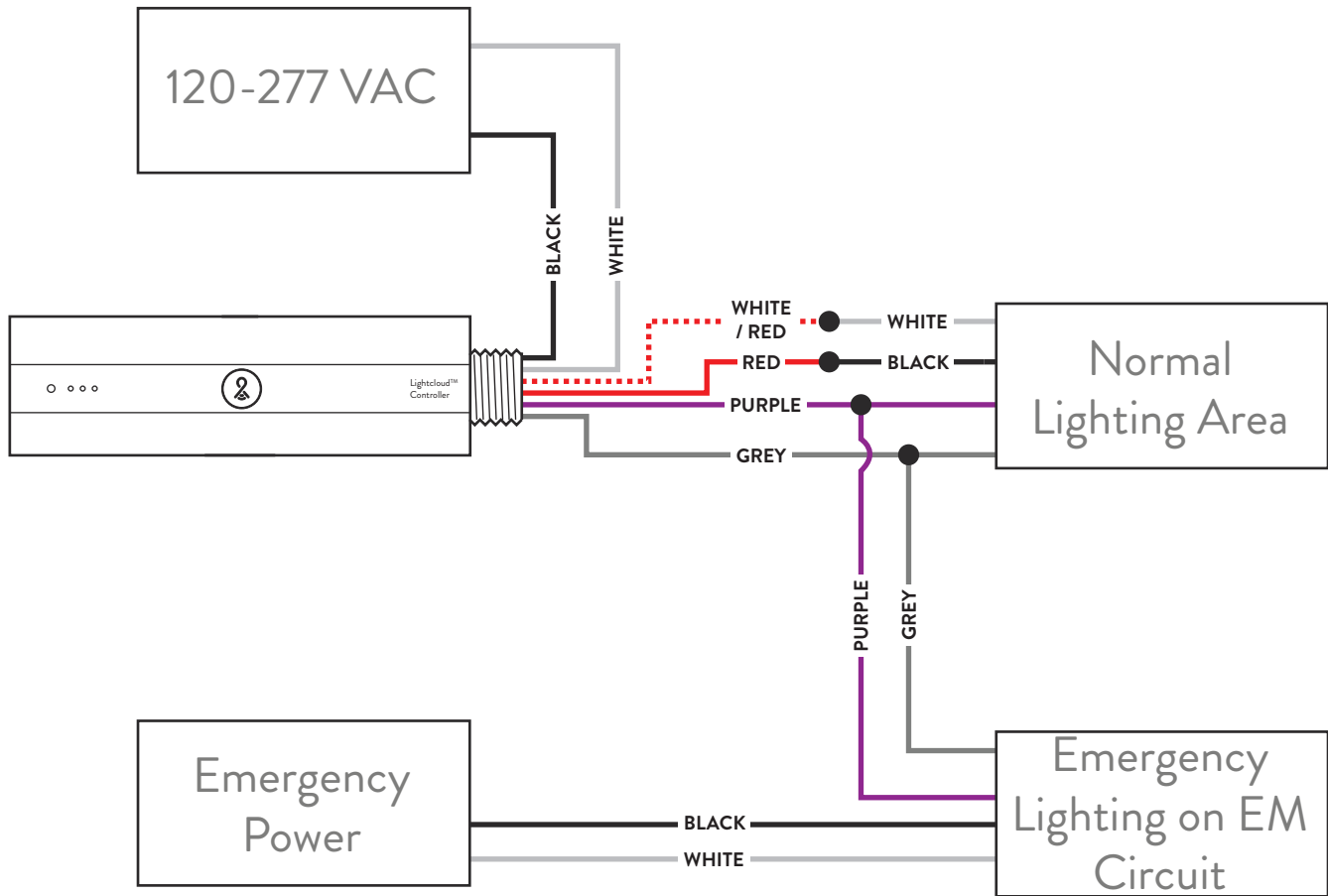

Notes: In spaces where there is only one luminaire, and it is connected to emergency power, the Controller will need to be connected to a Normal Power Circuit for proper operation. Emergency fixtures with on-board battery backup don't require special wiring.



Any wires not in use must be capped off or otherwise insulated.
This product should only be installed by a qualified electrician and in compliance with local and national electrical codes.

RAB

Controls



Lightcloud Emergency Shunt On/Off

Lightcloud Controller emergency fixture wiring with LCShunt for on/off operation.

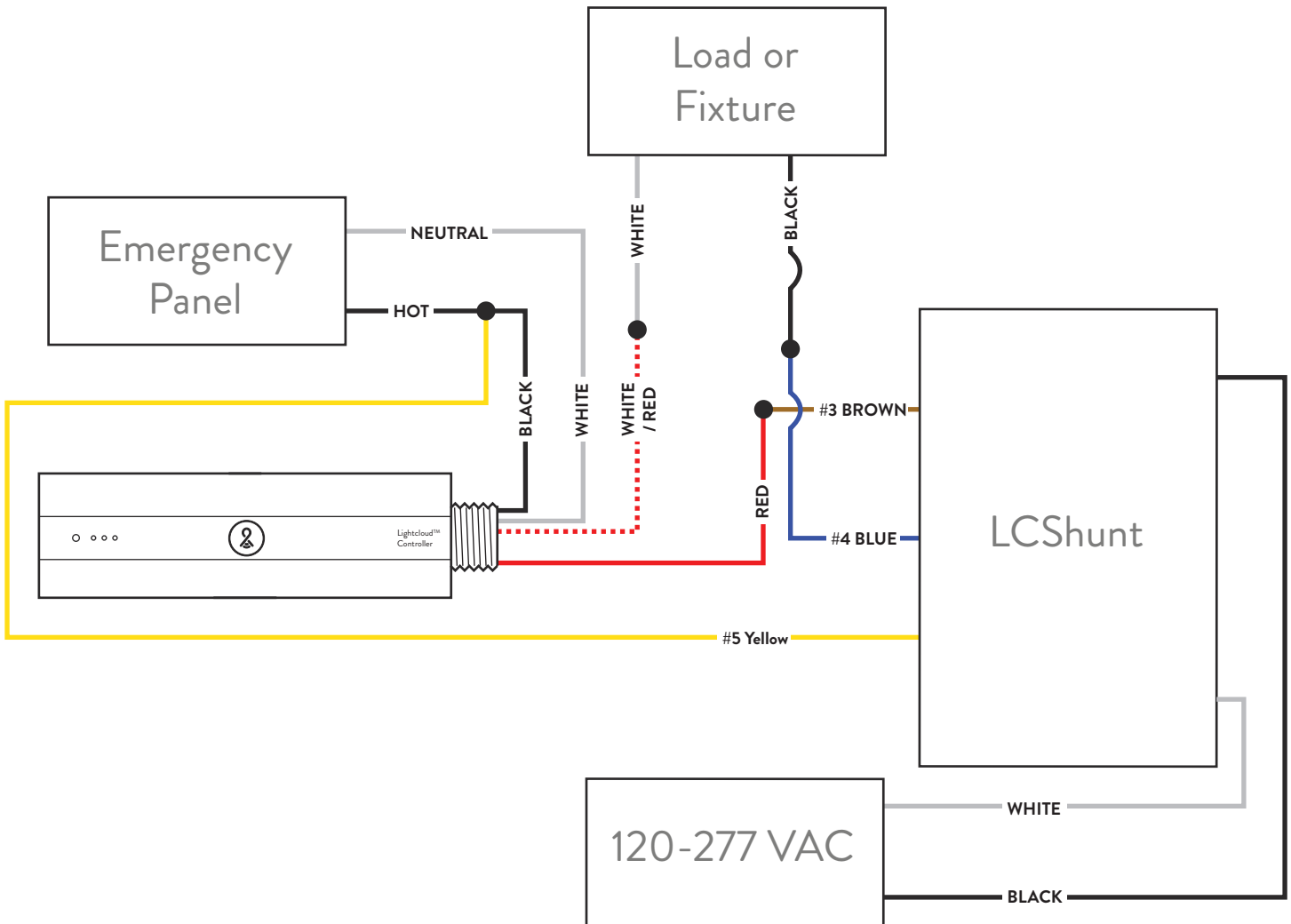

Note: The LESHUNT includes a 20A rated high voltage Form C (N/O+N/C) relay and is UL924 Listed for emergency lighting control applications. The LESHUNT can bypass a line voltage switch or dimmer, ensuring that an emergency fixture illuminates at full brightness during a utility power interruption.



Any wires not in use must be capped off or otherwise insulated.
This product should only be installed by a qualified electrician and in compliance with local and national electrical codes.

RAB

Controls



Lightcloud Emergency Shunt Dimming

Lightcloud Controller emergency fixture wiring with LCShunt/D10 for on/off and 0-10V dimmable operation.

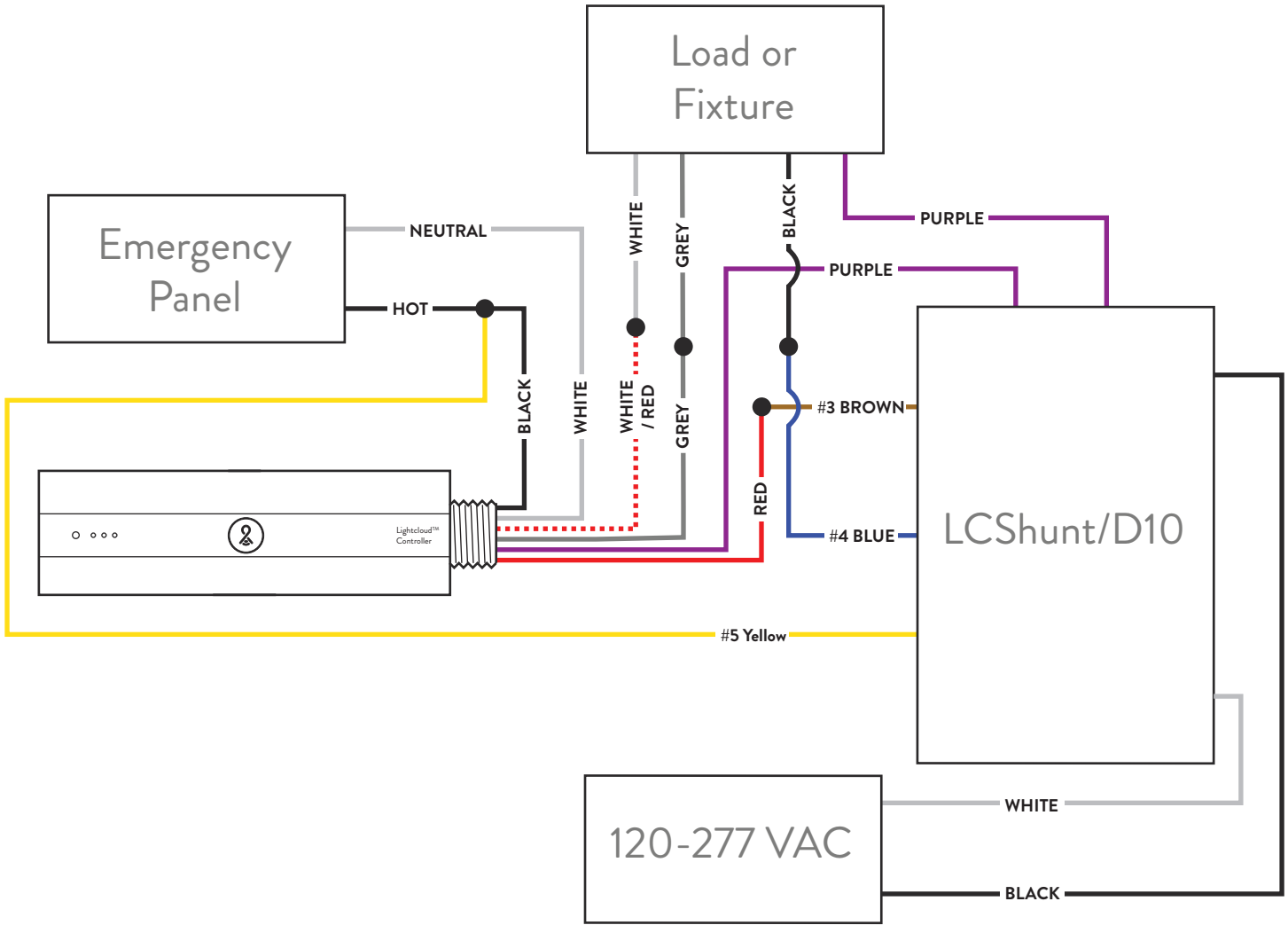

Note: The LESHUNT includes a 20A rated high voltage Form C (N/O+N/C) relay and a low voltage Form A (N/O) relay and is UL924 Listed for emergency lighting control applications. The LESHUNT can simultaneously bypass both a line voltage switch and a 0-10V dimming signal, ensuring that an emergency fixture illuminates at full brightness during a utility power interruption.



Any wires not in use must be capped off or otherwise insulated. This product should only be installed by a qualified electrician and in compliance with local and national electrical codes.

RAB

Controls



Lightcloud Phase Dimming <450W

Lightcloud Controllers can dim phase loads using a phase dimming adapter. For loads under 450W @ 120V and 1000W @ 277V, we recommend the Ecosense Ecospec adapter.

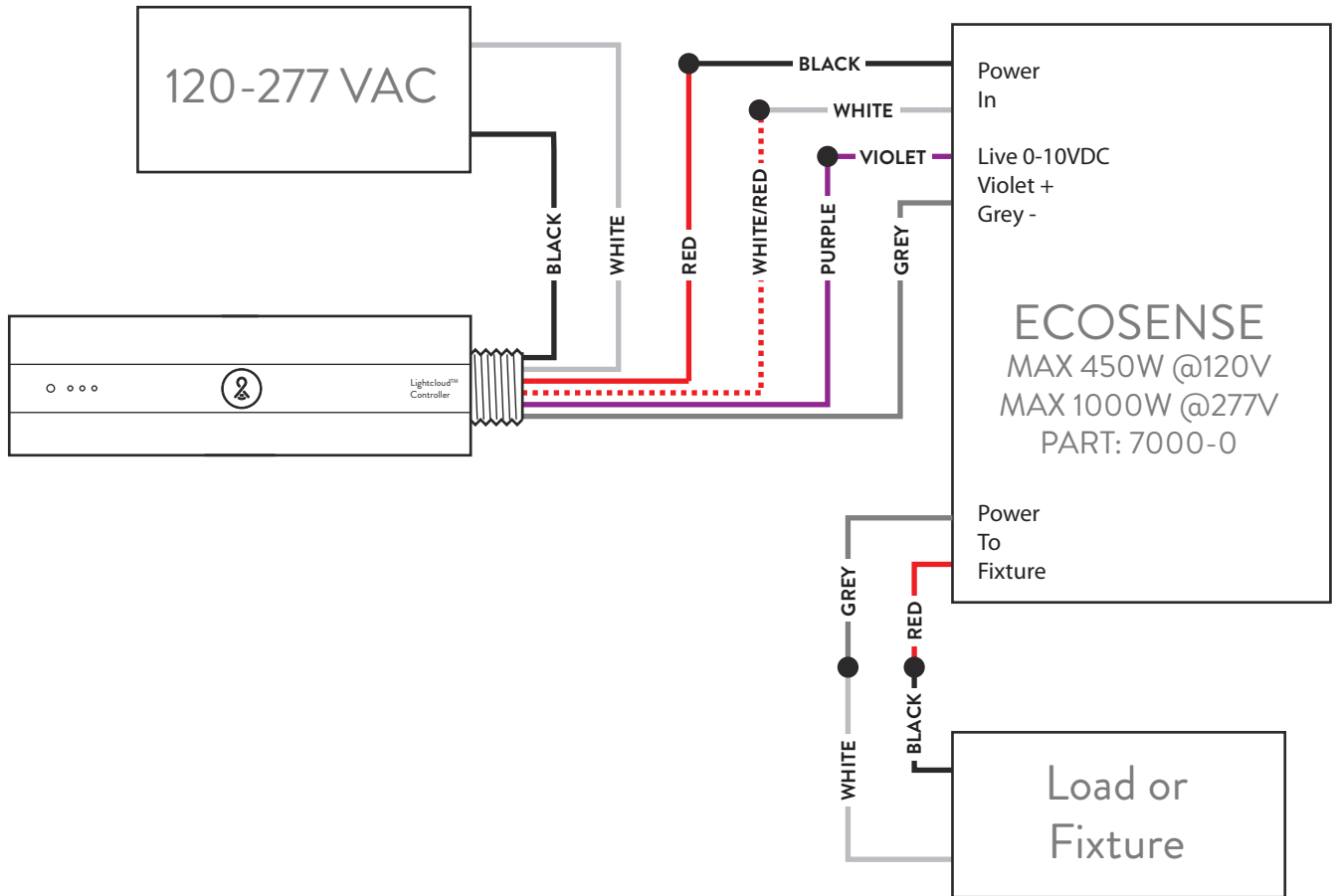

Phase Dimmer

Ecosense Ecospec Linear Dimming Control Module
450W MAX @ 120V
1000W MAX @ 277VD



Any wires not in use must be capped off or otherwise insulated.
This product should only be installed by a qualified electrician and in compliance with local and national electrical codes.

RAB

Controls



Lightcloud Phase Dimming 450-1800W

Lightcloud Controllers can dim phase loads using a phase dimming adapter. For loads between 450 and 1800W, we recommend the Lutron PHPM-PA-120-WH Phase Dimmer and BCI-0-10 Ballast Control Interface.

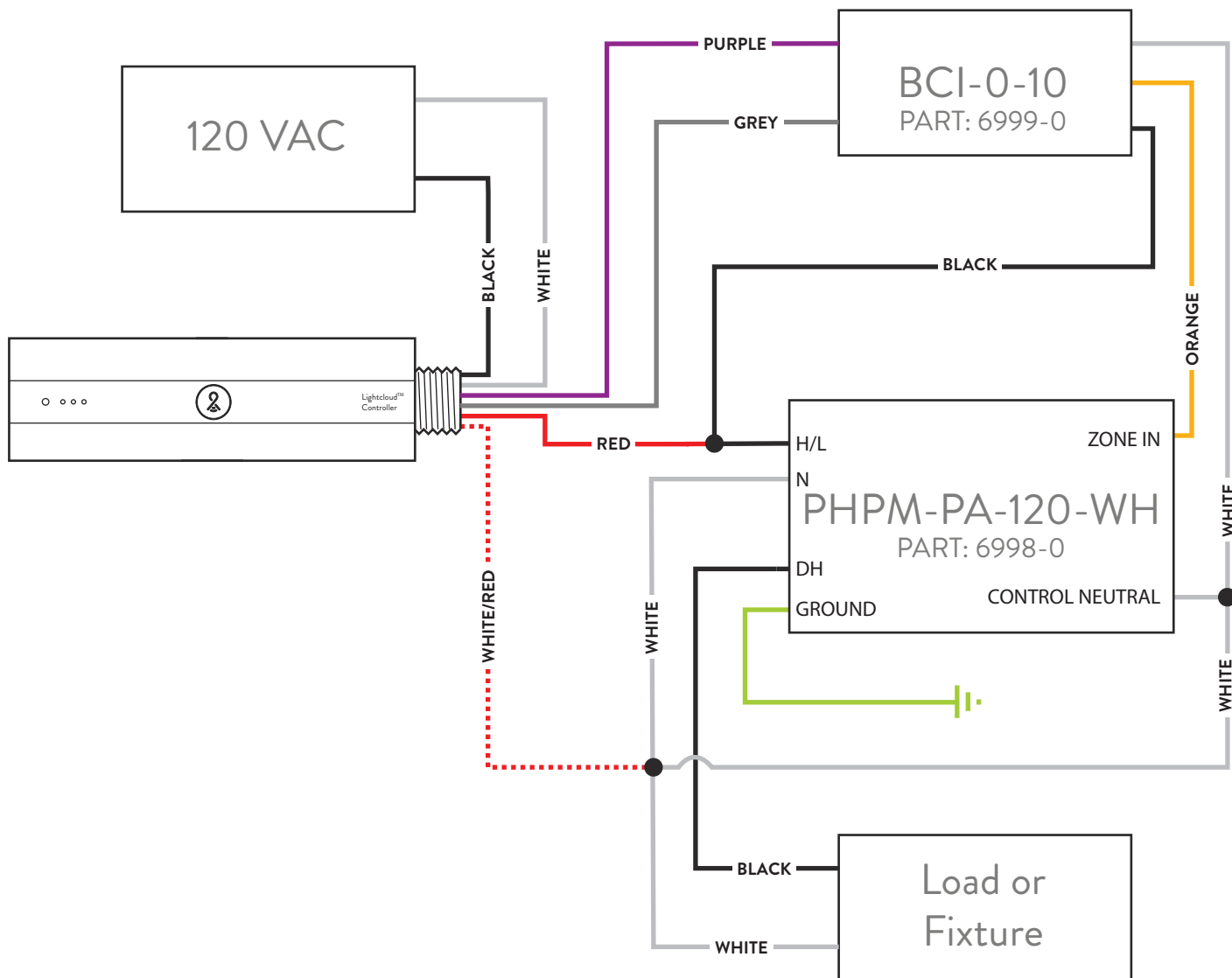

Phase Dimmer
 Lutron PHPM-PA-120-WH
 120 V @ 16 A

Ballast Control Interface
 Lutron BCI-0-10
 Control Input Voltage: 0-10 V-
 Control Input Current: Source 500 μ A
 Compatible Voltage: 120-277 V~ 50/60 Hz



Any wires not in use must be capped off or otherwise insulated.
 This product should only be installed by a qualified electrician and in compliance with local and national electrical codes.

RAB

Controls



Lightcloud Plug Load Control

Lightcloud Controllers can control electrical outlets using a contactor.

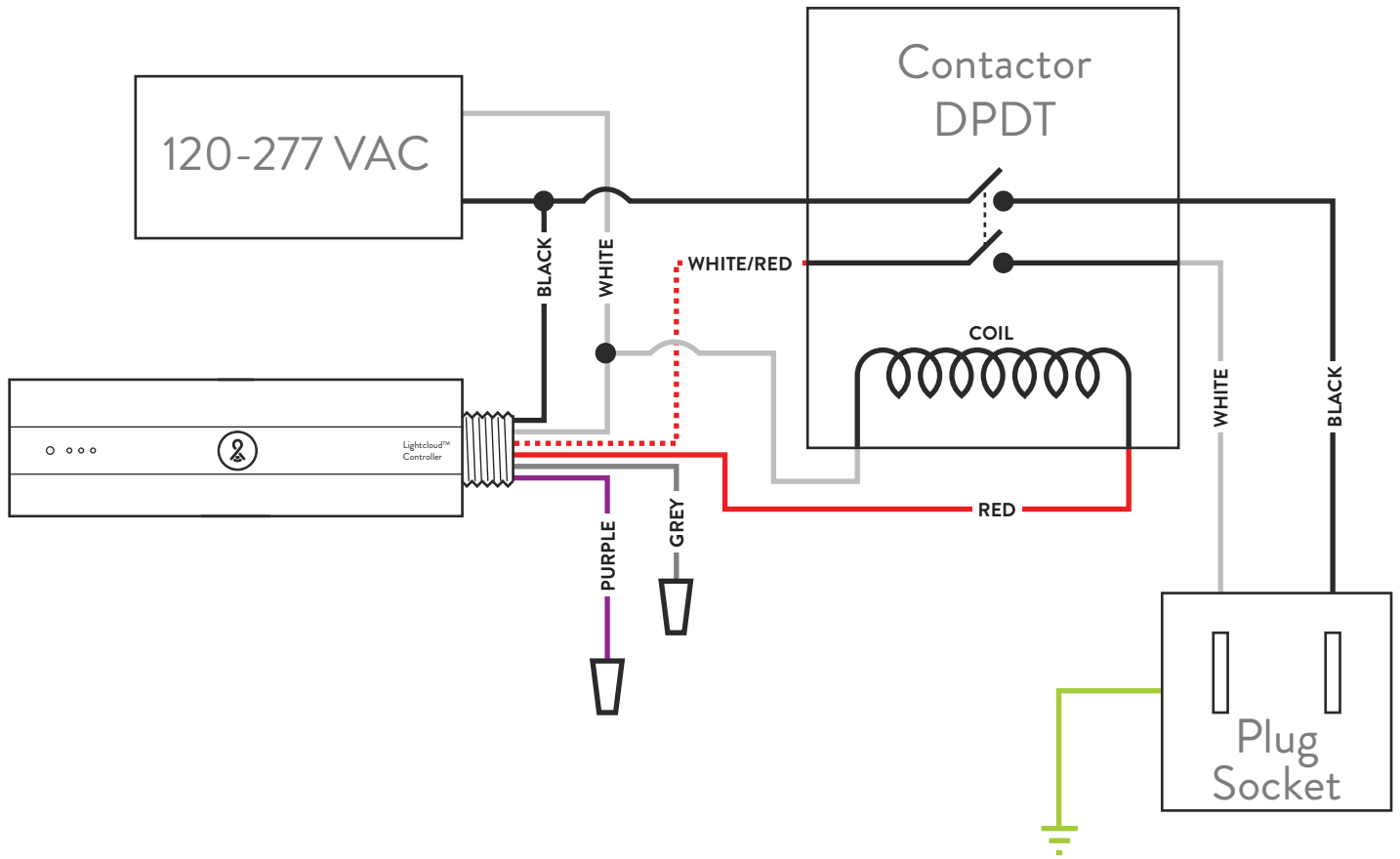

Any wires not in use must be capped off or otherwise insulated.
This product should only be installed by a qualified electrician and in compliance with local and national electrical codes.

RAB

Controls

Welcome



Lightcloud®

Luminaire Controller

LCLC3/D10

WE'RE HERE TO HELP:

1 (844) LIGHTCLOUD

1 (844) 544-4825

support@lightcloud.com

Hello

Lightcloud is a wireless lighting control system. The Lightcloud Luminaire Controller is a remotely controlled switching and dimming device that can be installed into luminaires.

Product Features

Wireless Control & Configuration

Switching up to 3A

0-10V Dimming

Power Monitoring

Patent Pending

Contents

Actuator Module, P/N 24586

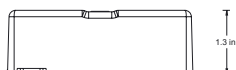
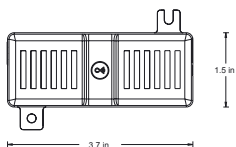
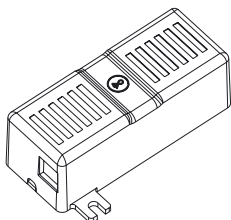

Radio Module, P/N 24572

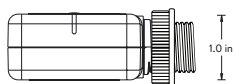
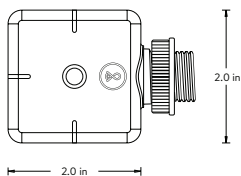
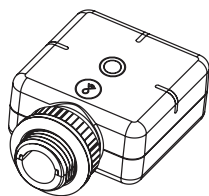

Wire Nuts



Gasket



Instruction Manual

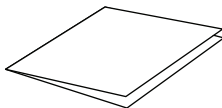

Specifications & Ratings

PART NUMBER

LCLC3/D10

INPUT

120/277VAC, 50/60Hz

CURRENT DRAW

<0.6W(Standby)-1W(Active)

LOAD SWITCHING CAPACITY

LED, CFL, Tungsten 120/277VAC 500W;
Magnetic 120VAC 264VA, 277VAC 500VA;
Resistive/Inductive 120VAC 500W

OPERATING TEMPERATURE:

-40°C to +50°C max temp

ACTUATOR MODULE OVERALL DIMENSIONS:

3.7" x 1.5" x 1.3"

RADIO MODULE OVERALL DIMENSIONS:

2" x 2" x 1"

WIRELESS RANGE

Line-of-Sight: 700 feet Obstructions: 70 feet

INDOOR USE ONLY

DAMP LOCATION

What You Need

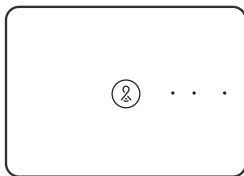

Lightcloud Gateway

A Lightcloud installation requires at least one Lightcloud Gateway to manage your devices.

WE'RE HERE TO HELP:

1 (844) LIGHTCLOUD

1 (844) 544-4825

support@lightcloud.com

Setup & Installation

1 Turn off power

 **WARNING**

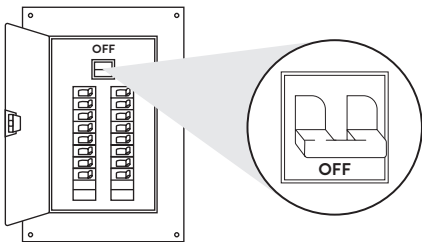

1a Find a Suitable Location

Use these guidelines when installing devices:

- If there is a clear line of sight between a Luminaire Controller and another Lightcloud device they can be placed up to 700 feet apart.
- If a Luminaire Controller and another Lightcloud device are separated by ordinary drywall construction, try to keep them within 70 ft. of each other.
- Brick, concrete and steel construction may require additional Lightcloud devices to go around the obstruction.

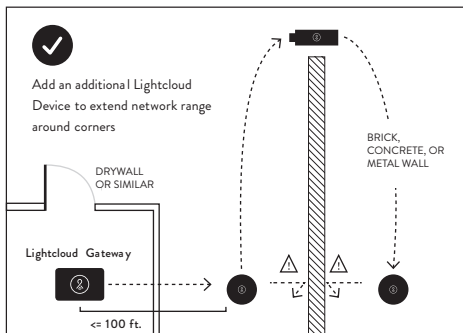

Setup & Installation (cont'd)

② Install the Luminaire Controller

For luminaires pre-installed with the Luminaire Controller, skip to Step 3.

2a Fixture Installation with Actuator Module Inside

If the interior of your luminaire can accommodate the dimensions of the actuator module, install the actuator module inside the housing, and attach the radio module to the outside of the housing via a knockout.

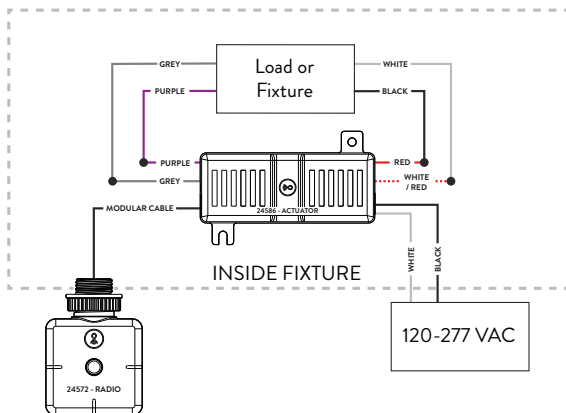

2b Installation with Junction Box

If the interior of your luminaire cannot accommodate the actuator module, the Luminaire Controller can be mounted into a junction box, with the radio module always outside any metal enclosure.

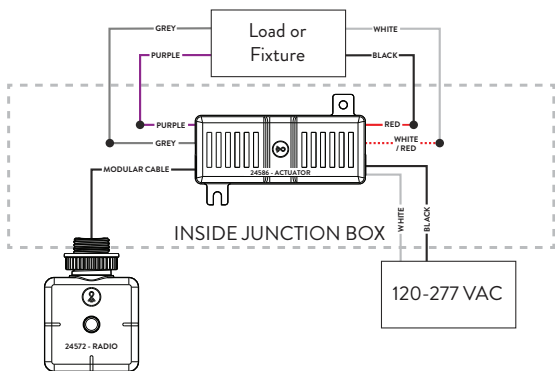

3 Install Luminaire

Install the luminaire with integrated Luminaire Controller as normal, allowing for any room to accommodate the external radio module of the LCLC3/D10.

Setup & Installation (cont'd)

④ Labeling your device

When installing devices, it's important to keep track of their Device IDs, installation locations, panel/circuit #s, dimming function, and any additional notes. To organize this information, use the Lightcloud Installer Application (A) or Device Table (B).

4a Lightcloud Installer Application

Install the LC Installer Application:

LC Installer is available for iOS and Android.

Scan & Install Lightcloud Devices:

Scan each device and assign to a room. It's recommended that each device is scanned just before or just after being wired so no devices are missed. The more notes that are given, the easier it is to commission the system.

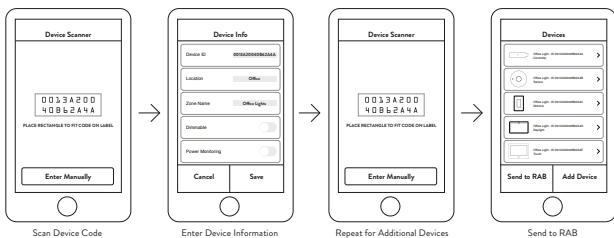

Send to RAB:

Once all of the devices have been added and organized, submit the information for commissioning.

Setup & Installation (cont'd)

4b Device Table

Two Lightcloud Device Tables are provided with each Gateway: one that you can attach to your panel and one to hand off to a building manager. Attach the Device Identification stickers included with each device to a row, then write in additional information, such as Zone name, Panel/Circuit Number, and whether or not a Zone uses dimming.

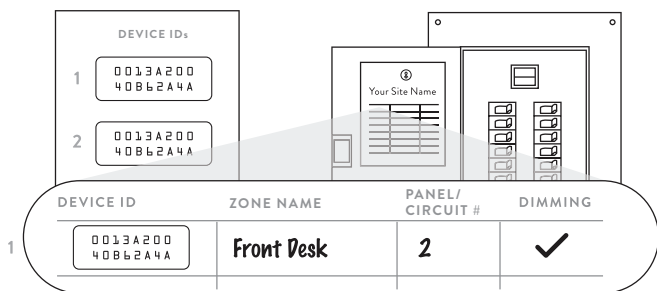

5 Power up

To add devices to your Lightcloud network, call RAB at 1 (844) LIGHTCLOUD, or email us at support@lightcloud.com

6 Confirm device connectivity

Confirm Status Indicator is Solid Green (see details below)

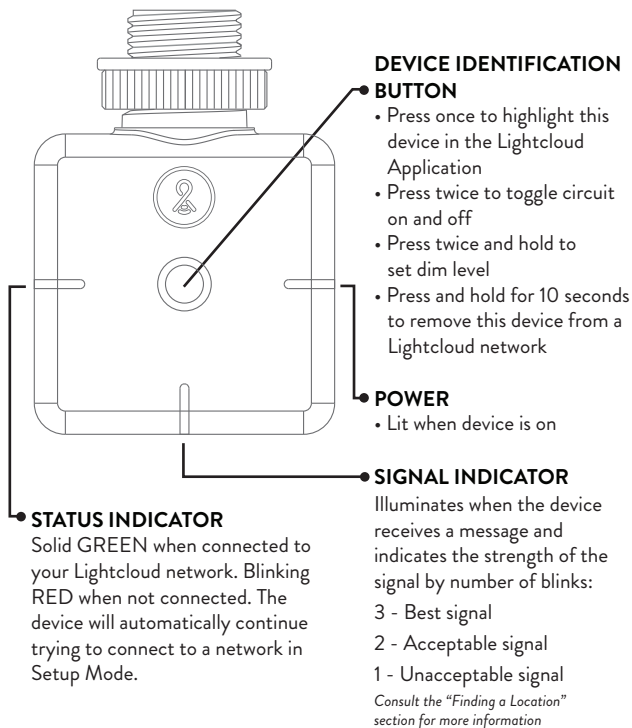

7 Commission your devices

Log on to www.lightcloud.com or call 1 (844) LIGHTCLOUD

Functionality

Configuration

All configuration of Lightcloud products may be performed using the Lightcloud web Application, or by calling RAB.

WE'RE HERE TO HELP:

1 (844) LIGHTCLOUD

1 (844) 544-4825

support@lightcloud.com

Power Measurement

The Lightcloud Luminaire Controller is capable of measuring the power usage of the attached luminaire. In order to utilize this function, the neutral wire of the load must be connected to the white-red neutral wire. If the white-red neutral line cannot be used, it should be tied to the regular neutral wires (i.e. all neutral wires joined).

Power Loss Detection

If mains power to the Controller is lost, the device will detect this and alert the Lightcloud Application.

Emergency Default

If communication is lost, the Controller may optionally fall back to a specific state, such as turning the attached luminaire on.

[Warning: Any wires not in use must be capped off or otherwise insulated.]

FCC Information:

This device complies with Part 15 of the FCC Rules. Operation is subject to the following two conditions: 1. This device may not cause harmful interference, and 2. This device must accept any interference received, including interference that may cause undesired operation.

Note: This device has been tested and found to comply with the limits for Class B digital devices pursuant to Part 15 Subpart B, of the FCC rules. These limits are designed to provide reasonable protection against harmful interference in a residential environment. This equipment generates, uses, and can radiate radio frequency energy, and if not installed and used in accordance with the instruction manual, may cause harmful interference to radio communications. However, there is no guarantee that interference will not occur in a particular installation. If this equipment does cause harmful interference to radio or television reception, which can be determined by turning the equipment of and on, the user is encouraged to try and correct the interference by one or more of the following measures:

- Reorient or relocate the receiving antenna.
- Increase the separation between the equipment and receiver.
- Connect the equipment into an outlet on a circuit different from that to which the receiver is connected.
- Consult the dealer or an experienced radio/TV technician for help.

To comply with the FCC's RF exposure limits for general population / uncontrolled exposure, this transmitter must be installed to provide a separation distance of at least 20 cm from all persons and must not be co-located or operating in conjunction with any other antenna or transmitter.

CAUTION: Changes or modifications to this equipment not expressly approved by RAB Lighting may void the user's authority to operate this equipment.



It's powerful and
flexible, yet easy to use
and install. Learn more at
lightcloud.com

1 (844) LIGHTCLOUD

1 (844) 544-4825

support@lightcloud.com

RAB | Controls

Custom manufactured in China

© RAB Lighting, Inc

170 Ludlow Avenue Northvale, NJ 07647