

# INSTRUCTIONS

## T10EM TUBE INSTALLATION

**RAB**<sup>®</sup>

RAB Lighting is committed to creating high-quality, affordable, well-designed and energy-efficient LED lighting and controls that make it easy for electricians to install and end users to save energy. We'd love to hear your comments. Please call the Marketing Department at 888-RAB-1000 or email: [marketing@rablighting.com](mailto:marketing@rablighting.com)



## IMPORTANT

### READ CAREFULLY BEFORE INSTALLING LAMPS. RETAIN THESE INSTRUCTIONS FOR FUTURE REFERENCE.

RAB lamps must be wired in accordance with the National Electrical Code and all applicable local codes. Proper grounding is required for safety. THIS PRODUCT MUST BE INSTALLED IN ACCORDANCE WITH THE APPLICABLE INSTALLATION CODE BY A PERSON FAMILIAR WITH THE CONSTRUCTION AND OPERATION OF THE PRODUCT AND THE HAZARDS INVOLVED.

**TYPE B LAMP** – Intended for operation in luminaires with traditional fluorescent-type lampholders wired directly to the branch circuit. This includes both factory-wired luminaires as well as those converted for this purpose under a retrofit program.

#### WARNINGS:

- Risk of fire or electric shock. LED Retrofit Kit installation requires knowledge of luminaires electrical systems. If not qualified, do not attempt installation. Contact a qualified electrician.
- Risk of fire or electric shock. Install this kit only in luminaires that have the construction features and dimensions shown in the photographs and/or drawings and where the input rating of the retrofit kit does not exceed the input rating of the luminaire.
- To prevent wiring damage or abrasion, do not expose wiring to edges of sheet metal or other sharp objects.
- To avoid potential fire or shock hazard, do not use this retrofit kit in luminaires employing shunted bi-pin lampholders.  
Note: Shunted lamp holders are found only in fluorescent luminaires with Instant-Start ballasts. Instant-start ballasts can be identified by the words "Instant Start" or "I.S." marked on the ballast. This designation may be in the form of a statement pertaining to the ballast itself, or may be combined with the marking for the lamps with which the ballast is intended to be used, for example F40T12/IS. For more information, contact the LED luminaire retrofit kit manufacturer.
- Installers should not disconnect existing wires from lampholder terminals to make new connections at lampholder terminals. Instead installers should cut existing lampholder leads away from the lampholder and make new electrical connections to lampholder lead wires by employing applicable connectors.

THE RETROFIT KIT IS ACCEPTED AS A COMPONENT OF A LUMINAIRE WHERE THE SUITABILITY OF THE COMBINATION SHALL BE DETERMINED BY AUTHORITIES HAVING JURISDICTION. PRODUCT MUST BE INSTALLED BY A QUALIFIED ELECTRICIAN IN ACCORDANCE WITH THE APPLICABLE AND APPROPRIATE ELECTRICAL CODES. THE INSTALLATION GUIDE DOES NOT SUPERSEDE LOCAL OR NATIONAL REGULATIONS FOR ELECTRICAL INSTALLATIONS

#### CAUTION:

Installers should examine all parts that are not intended to be replaced by the retrofit kit for damage and replace any damaged parts prior to installation of the retrofit kit.

- Disconnect power at the source before installation, inspection or removal. Do not simply switch off fixture.
- This item is rated at 120-277V. Installer must determine whether line voltage 120-277V is available at the luminaire before installation.
- Not intended for use with exit fixtures or exit lights.
- Over 90 minutes back up working time with typical 400 lumen output
- The battery in this device is not user serviceable. Refer service to manufacturer's qualified personnel only. Do not incinerate.
- Do not immerse the battery into the water or the sea, Guard against Damp
- Do not approach the heat source, like fire or heater;
- Do not discard the battery to the fire or hyperpyretic objects
- Please use the battery in normal as follows, or it will be overheating, caught fire, reduced performance and shorten the life;

#### Environment condition

(Temperature) charging: 0~+40°C (+32~+104°F)

Discharging: -20~+60°C (-4~+140°F)

Storage within: -20~+35°C (-4~+95°F). Storage humidity: 65±20%RH (Relative humidity)

- Risk of fire or electric shock. Do not open or modify. No user serviceable parts inside.
- Installers should not disconnect existing wires from lamp holder terminals to make new connections at lamp holder terminals. Instead installers should cut existing lamp holder leads away from the lamp holder and make new electrical connections to lamp holder lead wires by employing applicable connectors.
- SUITABLE FOR DAMP LOCATIONS. Not for use where directly exposed to the weather or water.
- SUITABLE FOR "TYPE IC" OR "TYPE NON-IC" LUMINAIRES.
- No external weight or mechanical force should be applied to tube or components.
- The operating instructions shall provide appropriate information regarding temperature limits during battery charging, use and storage, as well as for the safe disposal of the product.
- Do not make or alter any open holes in an enclosure of wiring or electrical components during kit installation.
- MIN. LAMP COMPARTMENT DIMENSIONS "121 cm(L) x 61 cm(W) x 5 cm(H)" [47.64inch(L) x 24inch(W) x 1.97inch(H)]

# INSTRUCTIONS

## T10EM TUBE INSTALLATION



RAB Lighting is committed to creating high-quality, affordable, well-designed and energy-efficient LED lighting and controls that make it easy for electricians to install and end users to save energy. We'd love to hear your comments. Please call the Marketing Department at 888-RAB-1000 or email: [marketing@rablighting.com](mailto:marketing@rablighting.com)

### LED TUBE INSTALLATION GUIDE

1. Disconnect power to the fixture.
2. Remove existing fluorescent tubes.
3. Remove ballast cover.
4. Cut all the wires to ballast. Note: Ballast must remain in place.
5. Remove existing lamp holders.
6. Replace existing lamp holders with new non-shunted lamp holders to install with the T10EM LED tube in the fixture. Refer to wiring diagram in (Fig. 1). (EM Test switch and non-shunted lamp holders sold separately).
7. Reinstall the ballast cover.
8. IMPORTANT: Turn on the battery connection switch near the red endcap (Fig. 3).  
The battery connection switch comes with a default "off" to prevent the built-in battery from being depleted and/or damaged.  
The lamp may be lit at a dim light level powered by the built-in battery.
9. Install the lamp in the lamp holders (Fig. 2), the lamp will have to be rotated to be locked into place and receive power.
10. Adhere the enclosed notice label to the reflector of the luminaire.
11. Restore power to the fixture and turn the light on with the wall switch.
12. The lamp should be lit at full power.
13. Regulatory compliance tests: Refer to EM Testing Guide.
14. Indicator working status (Fig.4).

Input Ratings				Lamp	LED Lamps Tested in Luminaire	Minimum Luminaire Dimension with Max. No. of Tubes	Lamp Holder to Lamp Holder Spacing
V	Hz	A	W	Length		Length x Width x Height	
120-277	50-60	0.16	17 (with battery fully charged)	48 inch	4	47.64 x 24 x 1.97 inch	4.33 inch
		0.18	21 (with battery in charging)				

Fig: 1



Fig: 2



Fig: 3



Fig: 4

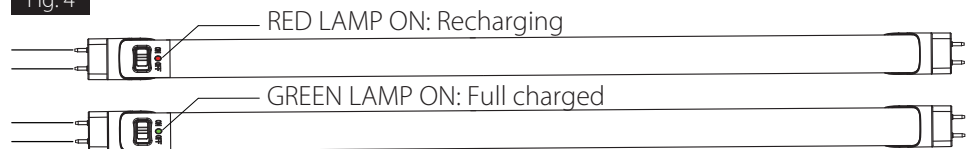

# INSTRUCTIONS

## T10EM-ACC KIT INSTALLATION



RAB Lighting is committed to creating high-quality, affordable, well-designed and energy-efficient LED lighting and controls that make it easy for electricians to install and end users to save energy. We'd love to hear your comments. Please call the Marketing Department at 888-RAB-1000 or email: [marketing@rablighting.com](mailto:marketing@rablighting.com)

## EM TEST SWITCH INSTALLATION INSTRUCTIONS

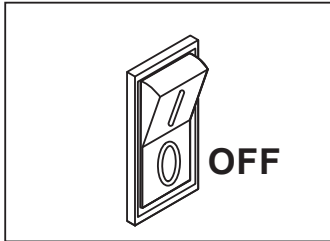

1. Switch-off the Power to Breaker 1.

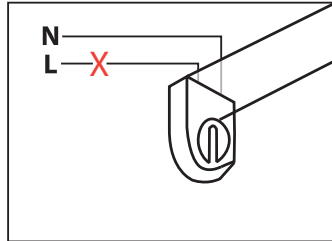

2. Cut 'L' wire. *Note: Ensure the lampholders are non-shunted ones.*

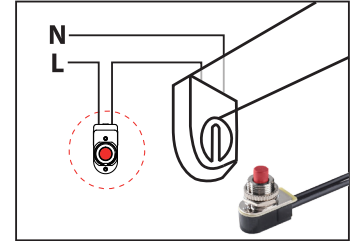

3. Connect Emergency Test Switch.

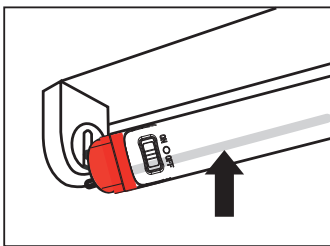

4. Install EM Tube. Ensure pins are firmly seated in lamp holders and rotate clockwise to lock them into place.

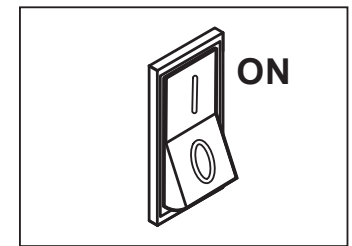
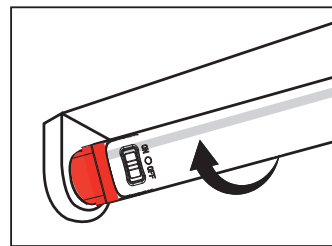

5. Switch on The Power to Breaker 1.

### NOTE:

If no existing Emergency Test Switch in the fixture system, you can follow these instructions after purchasing the relevant accessory kit from RAB Lighting.

If there is an existing Emergency Test Switch in the fixture system, you can replace the existing tubes and ensure the Test Switch can still work properly according to the EM TESTING GUIDE.

### EM TESTING GUIDE:

1. Press the test button to cut the power to the AC driver and switch the system to emergency mode.
2. Release the test button to return to normal mode.

## ROUTINE TESTING SCHEDULE

### Monthly

1. Ensure the wall switch Off.
2. Depress the test button and hold on.
3. Conduct a 30-second discharge test by depressing the test button.
4. The LED load should operate at reduced lumen output.

### Annually

1. Allow a 24-hours charge before conducting test.
2. Ensure the wall switch Off.
3. Keep the test button depressing or switch off the circuit Breaker 1.
4. Conduct a full 90-minute discharge test.
5. The unit should operate as intended for the duration of the test.

# INSTRUCTIONS

## T10EM-ACC KIT INSTALLATION



RAB Lighting is committed to creating high-quality, affordable, well-designed and energy-efficient LED lighting and controls that make it easy for electricians to install and end users to save energy. We'd love to hear your comments. Please call the Marketing Department at 888-RAB-1000 or email: [marketing@rablighting.com](mailto:marketing@rablighting.com)

### ACCESSORY PACKAGE



Lampholders



P3 wiring orange caps

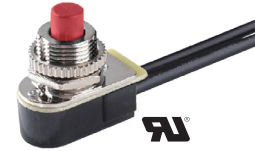

Emergency Test Switch

Accessory includes:

1. Two lampholders- one with white rotor, one with red rotor.
2. Two P3 wiring orange caps.
3. One Emergency Test Switch.

NOTE:

The set of accessory kit needs to be ordered separately.

### EM TEST SWITCH DRAWING

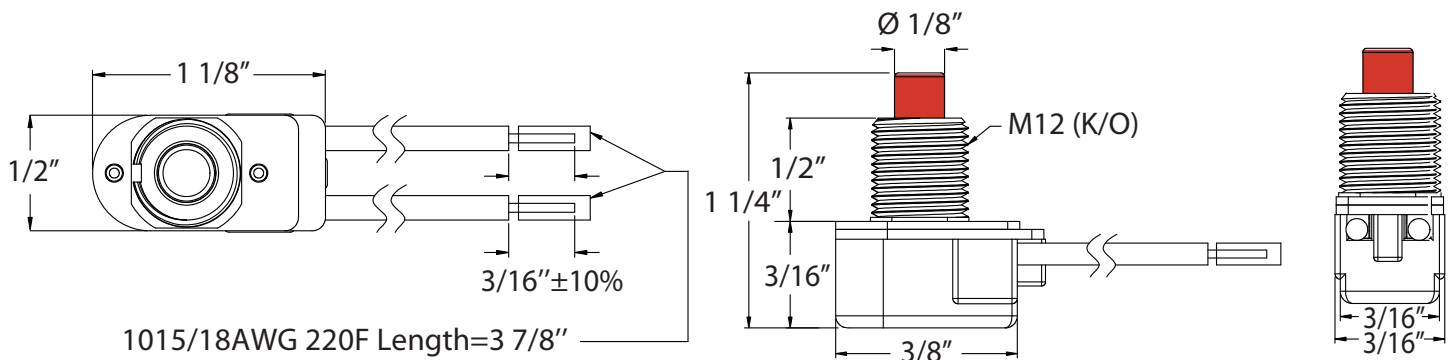

NFPA 101, Life Safety Code outlines the following schedule:

"Written records of the testing shall be kept by the owner for inspection by the authority having jurisdiction."

**Note:** These instructions do not cover all details or variations in equipment nor do they provide for every possible situation during installation, operation or maintenance.



© 2023 RAB LIGHTING Inc.  
Cranbury, New Jersey 08512 USA

### Easy Answers

[rablighting.com](http://rablighting.com)

Visit our website for product info

Tech Help Line

Call our experts: 888 722-1000

e-mail

Answered promptly - [sales@rablighting.com](mailto:sales@rablighting.com)

Free Lighting Layouts

Answered online or by request

T10EMACC-IN-1123

RAB WARRANTY: RAB's warranty is subject to all terms and conditions found at [rablighting.com/warranty](http://rablighting.com/warranty).