

# INSTRUCTIONS

## LED T8 Tube Series - Ballast Compatible & Ballast Bypass



RAB Lighting is committed to creating high-quality, affordable, well-designed and energy-efficient LED lighting and controls that make it easy for electricians to install and end users to save energy. We'd love to hear your comments. Please call the Marketing Department at 888-RAB-1000 or email: [marketing@rablighting.com](mailto:marketing@rablighting.com)



### IMPORTANT

#### READ CAREFULLY BEFORE INSTALLING FIXTURE. RETAIN THESE INSTRUCTIONS FOR FUTURE REFERENCE.

RAB LED tubes must be wired in accordance with the National Electrical Code and all applicable local codes. Proper grounding is required for safety. THIS PRODUCT MUST BE INSTALLED IN ACCORDANCE WITH THE APPLICABLE INSTALLATION CODE BY A PERSON FAMILIAR WITH THE CONSTRUCTION AND OPERATION OF THE PRODUCT AND THE HAZARDS INVOLVED.

This equipment has been tested and found to comply with the limits for a Class B digital device, pursuant to part 15 of the FCC Rules. These limits are designed to provide reasonable protection against harmful interference in a residential installation. This equipment generates, uses and can radiate radio frequency energy and, if not installed and used in accordance with the instructions, may cause harmful interference to radio communications. However, there is no guarantee that interference will not occur in a particular installation. If this equipment does cause harmful interference to radio or television reception, which can be determined by turning the equipment off and on, the user is encouraged to try to correct the interference by one or more of the following measures:

- Reorient or relocate the receiving antenna.
- Increase the separation between the equipment and receiver.
- Connect the equipment into an outlet on a circuit different from that to which the receiver is connected.
- Consult the dealer or an experienced radio/TV technician for help.

#### WARNING:

1. LED Luminaire Retrofit Kit Including LED Tube, Installation instructions, Luminaire Marking Label.
2. Risk of fire or electric shock. LED Retrofit Kit installation requires knowledge of luminaires electrical systems. If not qualified, do not attempt installation. Contact a qualified electrician in accordance with the National Electrical Code and relevant local code. 0-10V / Phase cut dimming with specified dimmers only.
3. Risk of fire or electric shock. Install this kit only in the luminaires that have the construction features and dimensions shown in the photographs and/or drawings and where the input rating of the retrofit kit does not exceed the input rating of the luminaire.
4. To prevent wiring damage or abrasion, do not expose wiring to edges of sheet metal or other sharp objects. Do not make or alter any open holes in an enclosure of wiring or electrical components during kit installation. This device is not intended for use with emergency exits. This item is rated at 120-277V. Installer must determine whether line voltage 120-277V is available at the luminaire before installation. SUITABLE FOR DAMP LOCATIONS.
5. Installers should not disconnect existing wires from lampholder terminals to make new connections at lampholder terminals. Instead installers should cut existing lampholder leads away from the lampholder and make new electrical connections to lampholder lead wires by employing applicable connectors.
6. THIS RETROFIT KIT IS ACCEPTED AS A COMPONENT OF A LUMINAIRE WHERE THE SUITABILITY OF THE COMBINATION SHALL BE DETERMINED BY AUTHORITIES HAVING JURISDICTION.
7. To avoid potential fire or shock hazard, do not use this retrofit kit in luminaires employing shunted bi-pin lampholders. Note: Shunted lamp holders are found only in fluorescent luminaires with Instant-Start ballasts. Instant-start ballasts can be identified by the words "Instant Start" or "I.S." marked on the ballast. This designation may be in the form of a statement pertaining to the ballast itself, or may be combined with the marking for the lamps with which the ballast is intended to be used, for example F40T12/IS. For more information, contact the LED luminaire retrofit kit manufacturer.

### INSTALLATION INSTRUCTIONS-Ballast Compatible

1. Turn Power OFF.

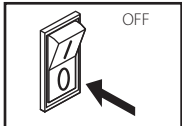

2. Remove lens or diffuser (if applicable).
3. Remove existing fluorescent lamps from the luminaire.

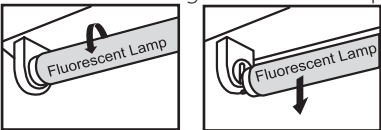

4. Select desired CCT level using the switch on LED lamp.

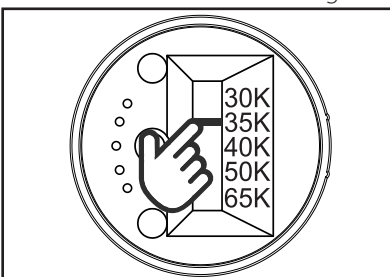

5. Bring LED lamp to luminaire and insert lamp pins into luminaire lamp holders.
6. Rotate LED lamp until lamp locks in place. Ensure that the LED lamp front points away from the back of the luminaire.

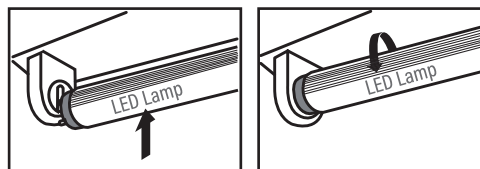

7. Place lens or diffuser back in place (if applicable).
8. Switch power ON.

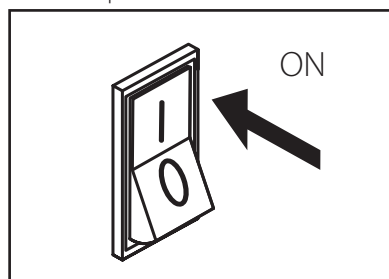

# INSTRUCTIONS

## LED T8 Tube Series - Ballast Compatible & Ballast Bypass



RAB Lighting is committed to creating high-quality, affordable, well-designed and energy-efficient LED lighting and controls that make it easy for electricians to install and end users to save energy. We'd love to hear your comments. Please call the Marketing Department at 888-RAB-1000 or email: [marketing@rablighting.com](mailto:marketing@rablighting.com)

### PRODUCT NOTES

The products are intended to retrofit type IC or Non-IC recessed mount listed fluorescent luminaires with instructions to remove the existing trim. Use maximum four straight tubular lamps with or without a diffuser. The minimum lamp compartment dimensions are tabulated on the right: Manufactured by RAB Lighting Inc.

Part Number	MINIMUM LAMP COMPARTMENT DIMENSIONS (cm/inch)	
T10370 (T8-12-48G-8CCT-HYB)	122 x 56 x 5 cm	48.03 x 22.04 x 1.96 inch
T10371 (T8-15-48G-8CCT-HYB)	122 x 56 x 5 cm	48.03 x 22.04 x 1.96 inch
Maximum Lamp quantity in Luminaire	4	

### INSTALLATION INSTRUCTIONS-Ballast Bypass DOUBLE-ENDED POWER

1. Make sure the circuit breaker that supplies the power to the fixture is turned off.
2. Remove lens or diffuser cover (if applicable) and existing fluorescent lamps.
3. Open/Remove ballast wiring compartment cover.
4. Identify the line and neutral wires running from the breaker box to the ballast and confirm the power is off using a voltmeter.
5. Cut all wires connected to ballast, Dispose of removed ballast and fluorescent lamps in accordance with government regulations in your area.
6. Ensure that the fixture contains shunted G13 bi-pin lamp holders. If socket lamp holders are non-shunted, replace with new shunted socket lamp holders, or shunted with a jumper wire to convert into shunted sockets.
7. LED T8 lamps are designed for double sided connections only (Fig. 1). To install, please wire non-shunted sockets by connecting one wire from the lamp holder to branch circuit L (LIVE) and the other wire at the opposite end to branch circuit N (NEUTRAL). Do not connect opposite side to power. Use appropriate wires for connection.

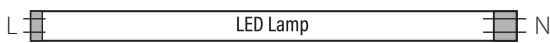

Fig. 1 - Double sided connections

8. Make sure all sockets are replaced and wired according to the appropriate wiring diagram. (Fig. 2, 3, 4, 5).

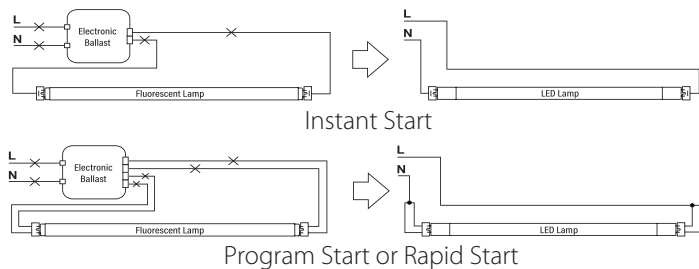

Fig. 2 - Retrofit luminaire with One Lamp

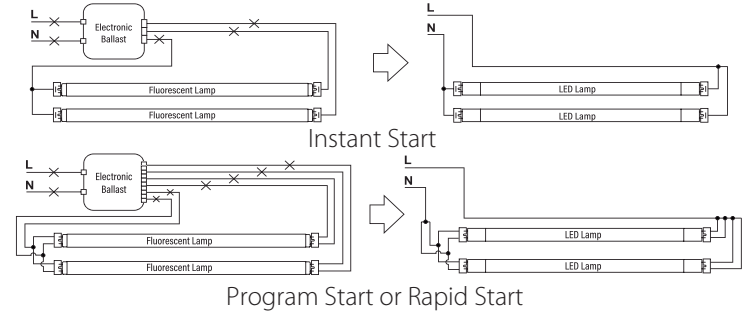

Fig. 3 - Retrofit luminaire with Two Lamps

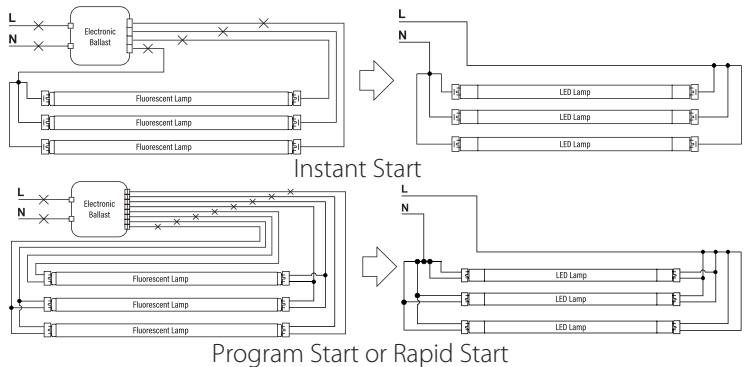

Fig. 4 - Retrofit luminaire with Three Lamps

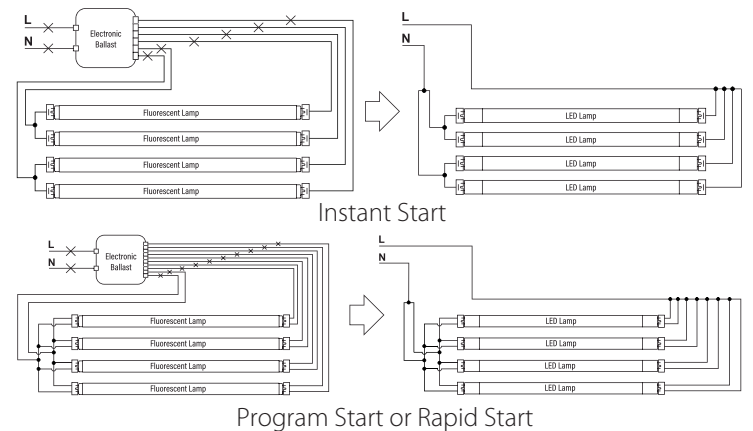

Fig. 5 - Retrofit luminaire with Four Lamps

9. Reinstall the ballast cover to hide all wires.
10. Install your new LED T8 replacement lamps.
11. Apply Relamping Label on a visible location inside the fixture.
12. Reinstall lens or diffusion cover on the light fixture.
13. Turn power on at the breaker box.
14. Turn on the lights.

**Note:** These instructions do not cover all details or variations in equipment nor do they provide for every possible situation during installation, operation or maintenance.

RAB Lighting is committed to creating high-quality, affordable, well-designed and energy-efficient LED lighting and controls that make it easy for electricians to install and end users to save energy. We'd love to hear your comments. Please call the Marketing Department at 888-RAB-1000 or email: [marketing@rablighting.com](mailto:marketing@rablighting.com)

### INSTALLATION INSTRUCTIONS-Ballast Bypass SINGLE-ENDED POWER

1. Turn Power OFF.
2. If applicable, replace lamp holders at power end with non-shunted lamp holders (Fig.6).

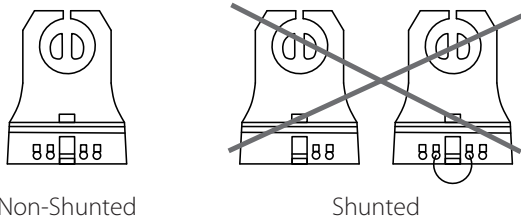

Fig: 6

3. Install lamp with the L and N markings into the wired lamp holder end (Fig.7).



Fig: 7

4. If installing a single tube refer to Fig. 8. If connecting multiple lamps, connect separate neutral wire into "Neutral out" from primary source lamp holder and connect that wire into "Neutral in" on the adjacent tube. See Fig. 9 below.

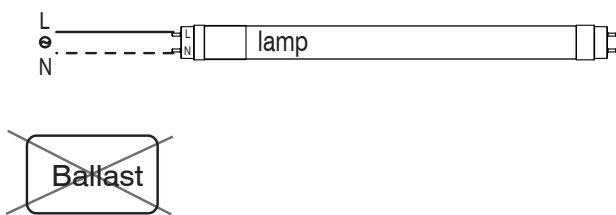

Fig: 8

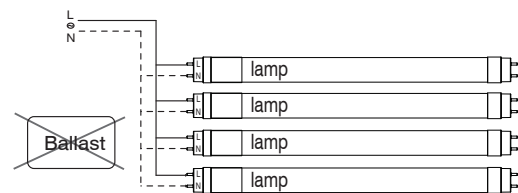

Fig: 9