

INSTRUCTIONS

FIELD-ADJUSTABLE X22™ INSTALLATION

RAB®

RAB Lighting is committed to creating high-quality, affordable, well-designed and energy-efficient LED lighting and controls that make it easy for electricians to install and end users to save energy. We'd love to hear your comments. Please call the Marketing Department at 888-RAB-1000 or email: marketing@rablighting.com



IMPORTANT

READ CAREFULLY BEFORE INSTALLING FIXTURE. RETAIN THESE INSTRUCTIONS FOR FUTURE REFERENCE.

RAB fixtures must be wired in accordance with the National Electrical Code and all applicable local codes. Proper grounding is required for safety. THIS PRODUCT MUST BE INSTALLED IN ACCORDANCE WITH THE APPLICABLE INSTALLATION CODE BY A PERSON FAMILIAR WITH THE CONSTRUCTION AND OPERATION OF THE PRODUCT AND THE HAZARDS INVOLVED.

WARNING: Make certain power is OFF before installing or maintaining fixture. No user serviceable parts inside.

Suitable for wet locations. Min 75° supply conductors.

Suitable for operation in ambient temperature not exceeding 50° C.

KNUCKLE MOUNTING

(Suitable for X22-20, X22-35, X22-60, X22-80)

To ensure weatherproof seal, apply weatherproof silicone sealant around the edge of the junction box (*by others*). This is especially important with an uneven wall surface.

1. Secure the fixture to a 1/2" NPS threaded hole in the junction box or landscape post (*Fig. 1*). Seal arm thread using Teflon® tape or silicone sealant.
2. Make appropriate wire connections per NEC in an approved enclosure (*by others*) see Fig. 20 and 21. Cap off individual dimming wires if unused.
3. The **Knuckle Arm** allows 180° of vertical aiming adjustment depending on the mounting position as shown in Fig. 2.

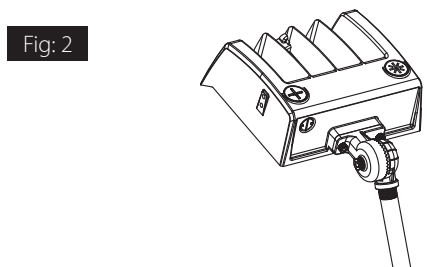
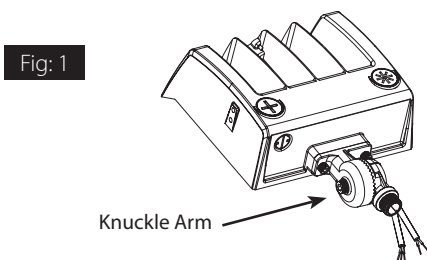

YOKE MOUNTING

(Suitable for X22-20, X22-35)

To ensure weatherproof seal, apply weatherproof silicone sealant around the edge of the junction box (*by others*). This is especially important with an uneven wall surface.

1. Remove pre-installed **Knuckle Arm** (*Fig. 3*).
2. Mount **Yoke** to fixture housing and secure with provided **Screws (4)**, see Fig. 4 and 5.
3. Make appropriate wire connections per NEC in an approved enclosure (*by others*) see Fig. 20 and 21. Cap off individual dimming wires if unused.
4. The **Yoke** allows 180° of vertical aiming adjustment depending on the mounting position as shown in Fig. 6.

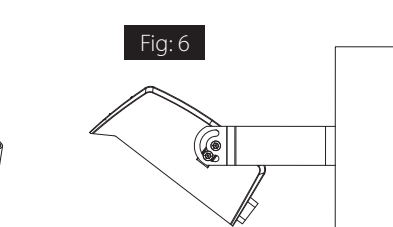
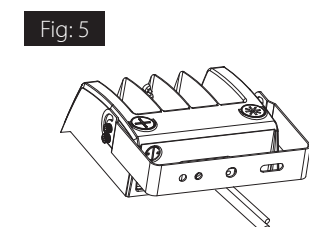
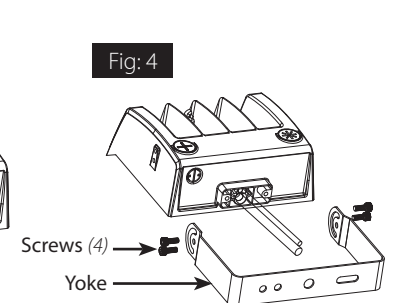
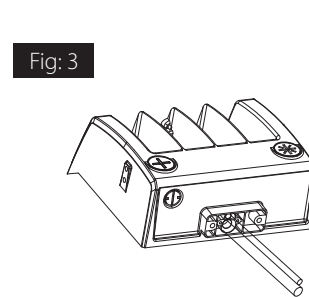

INSTRUCTIONS

FIELD-ADJUSTABLE X22™ INSTALLATION

RAB®

RAB Lighting is committed to creating high-quality, affordable, well-designed and energy-efficient LED lighting and controls that make it easy for electricians to install and end users to save energy. We'd love to hear your comments. Please call the Marketing Department at 888-RAB-1000 or email: marketing@rablighting.com

TRUNNION MOUNTING

(Suitable for X22-60, X22-80)

1. Remove **Knuckle Arm**.
2. Secure the **Trunnion** (provided) to the **Fixture** housing using provided **Pivot/Locking Screws** (2) as shown in Fig. 7, 8, 9.
3. Make appropriate wire connections per NEC in a approved enclosure (by others) see Fig. 20 and 21.
4. Loosen the **Pivot** and **Angle Locking Screws** to adjust the **Fixture** to desired angle as shown in Fig. 10.
5. Tighten **Pivot** and **Angle Locking Screws**.

Fig. 7

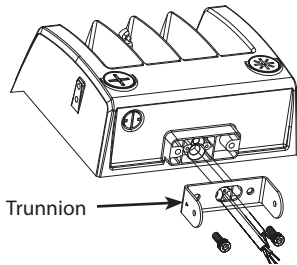

Fig. 8

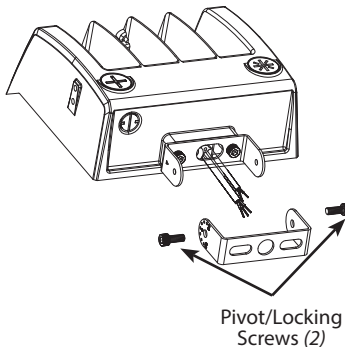

Fig. 9

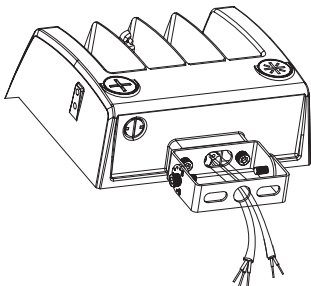
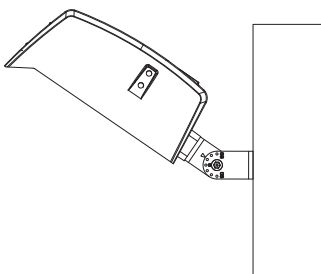

Fig. 10



TRUNNION MOUNTING

(Suitable for X22-150)

1. Remove **Slipfitter** and retain (4) **Allen Bolts** (Fig. 12).
2. Secure the **Trunnion** bracket to Fixture with (4) **Allen Bolts** (Fig. 13).
3. Mount **Trunnion** bracket to the mounting surface using appropriate hardware (by others).
4. Make appropriate wire connections per NEC in an approved enclosure (by others) see Fig. 21.
5. Loosen the **Locking Bolt** (Fig. 14) and swivel the Fixture to the desired angle.
6. Tighten the **Locking Bolt**.

Fig. 13

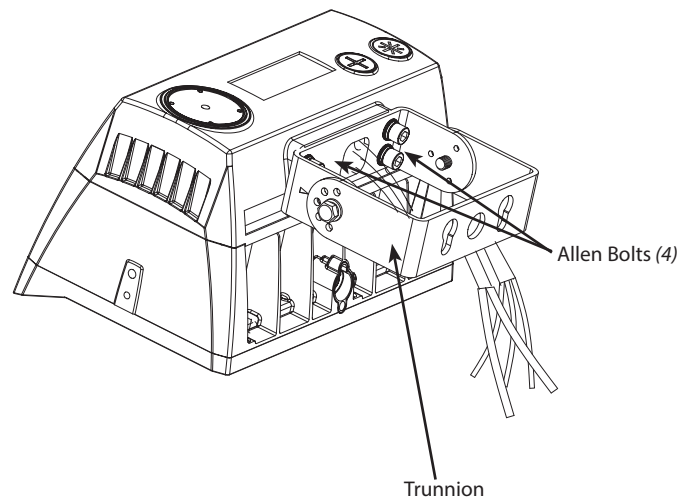
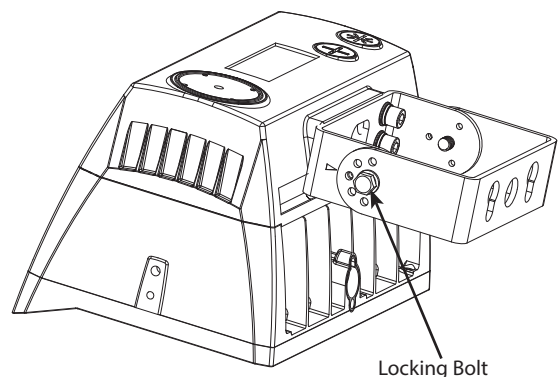

Fig. 14



INSTRUCTIONS

FIELD-ADJUSTABLE X22™ INSTALLATION



RAB Lighting is committed to creating high-quality, affordable, well-designed and energy-efficient LED lighting and controls that make it easy for electricians to install and end users to save energy. We'd love to hear your comments. Please call the Marketing Department at 888-RAB-1000 or email: marketing@rablighting.com

SLIPFITTER MOUNTING

(Suitable for X22-150)

WARNING: RISK OF SERIOUS INJURY OR DEATH!
DO NOT MOUNT THE SLIPFITTER TO A TENON OR BRACKET THAT IS MORE THAN 20 DEGREES FROM VERTICAL. MOUNTING ANY ANGLE OTHER THAN 0-20° DEGREES INCREASES THE RISK OF DISENGAGEMENT AND/OR FAILURE OF THE SLIPFITTER. INSTALL THE POLE ON A SECURE BASE OR INSTALL THE BRACKET TO A WALL FIRST, THEN PLACE LUMINAIRE ONTO THE POLE OR BRACKET. DO NOT LIFT ASSEMBLED LUMINAIRE AND POLE, OR LUMINAIRE AND BRACKET, LUMINAIRE OR POLE/BRACKET MAY DISENGAGE.

1. Make appropriate wire connections per NEC (Fig. 21).
2. Place the **Slipfitter** over the **Tenon** and secure the **Fixture** with **Set Screws (4)** on the side of the **Slipfitter** as shown in Fig 11.
3. Loosen the **Locking Bolt** and swivel the **Fixture** to the desired angle. Adjustable angle is 0~+/-90° (Fig. 12).
4. Tighten the **Locking Bolt**.

Fig: 11

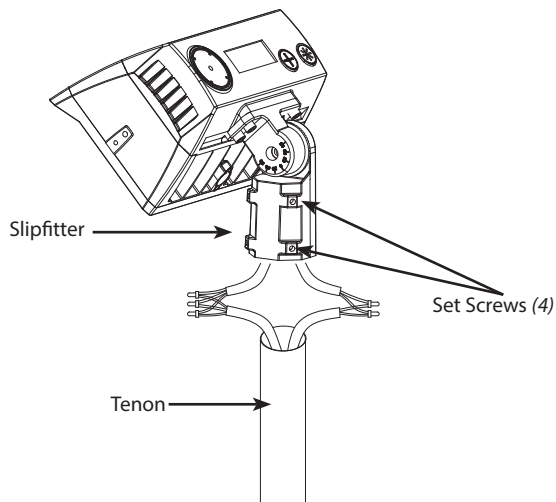
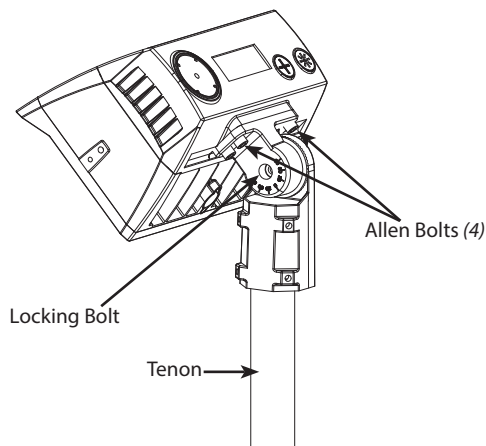

Fig: 12



BEAM ANGLE ADJUSTMENT

(Suitable for X22-20, X22-35, X22-60, X22-80)

Follow instructions below to change fixture **Beam Angle**. Selectable options are 55°/75°/90°.

Factory Settings: 90°

1. Locate **Beam Angle Selector** on the top of **Housing** as shown in Fig. 15 and select desired Beam Angle.
2. Use provided **Key/Tool** to adjust the Beam Angle (Fig. 17).

Fig. 15

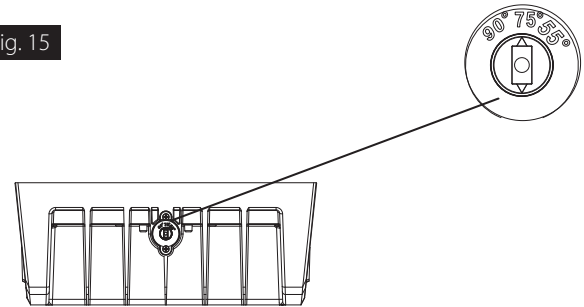

BEAM ANGLE ADJUSTMENT

(Suitable for X22-150)

Follow instructions below to change fixture **Beam Angle**. Selectable options are 55°/75°/90°.

Factory Settings: 90°

1. Locate **Beam Angle Selector** on the bottom of **Housing** as shown in Fig. 16 and select desired Beam Angle.
2. Use provided **Key/Tool** to adjust the Beam Angle (Fig. 17).

Fig. 16

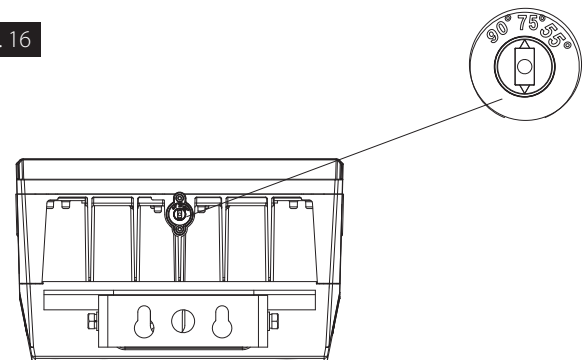
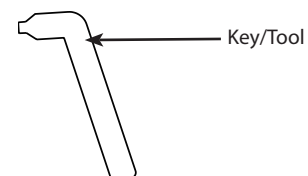

Fig. 17



INSTRUCTIONS

FIELD-ADJUSTABLE X22™ INSTALLATION



RAB Lighting is committed to creating high-quality, affordable, well-designed and energy-efficient LED lighting and controls that make it easy for electricians to install and end users to save energy. We'd love to hear your comments. Please call the Marketing Department at 888-RAB-1000 or email: marketing@rablighting.com

FIELD ADJUSTMENT

(Suitable for X22-20, X22-35, X22-60, X22-80)

Follow instructions below to change fixture Color Temperature (CCT), Power (W) and/or Photocell On/Off option from the factory setting:

Factory Settings: Max wattage, 4000K, Photocell/ON

1. Locate **Selector Switches** on back of **Housing** as shown in Fig. 18 and remove **Plugs**.
2. Select Color Temperature (CCT), Power (W) and/or Photocell On-Off position by sliding the respective switch to the desired value (Fig. 19).
3. Re-install **Selector Switch Plugs**.

Fig. 18

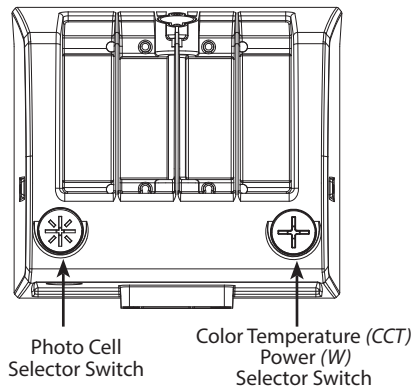

FIELD ADJUSTMENT

(Suitable for X22-150)

Follow instructions below to change fixture Color Temperature (CCT), Power (W) and/or Photocell On/Off option from the factory setting:

Factory Settings: Max wattage, 4000K, Photocell/ON

1. Locate **Selector Switches** on back of **Housing** as shown in Fig. 19 and remove **Plugs**.
2. Select Color Temperature (CCT), Power (W) and/or Photocell On-Off position by sliding the respective switch to the desired value (Fig. 19).
3. Re-install **Selector Switch Plugs**.

Fig. 18

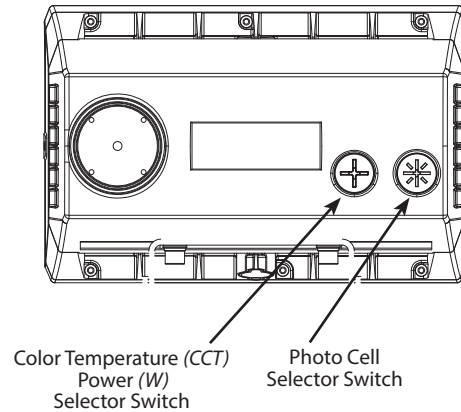
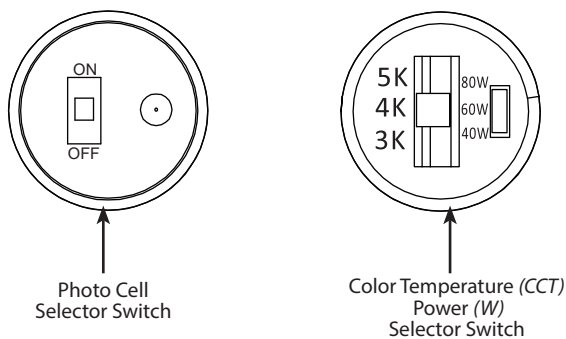

Fig. 19



INSTRUCTIONS

FIELD-ADJUSTABLE X22™ INSTALLATION

RAB®

RAB Lighting is committed to creating high-quality, affordable, well-designed and energy-efficient LED lighting and controls that make it easy for electricians to install and end users to save energy. We'd love to hear your comments. Please call the Marketing Department at 888-RAB-1000 or email: marketing@rablighting.com

0-10V DIMMABLE WIRING

(Suitable for X22-20, X22-35, X22-60)

Universal voltage driver permits operation at 120V through 277V, 50 or 60 Hz. For 0-10V dimming follow the wiring directions as shown in Fig. 20.

1. Connect the black fixture lead to the **LINE** supply lead.
2. Connect the white fixture lead to the **COMMON** supply lead.
3. Connect the **GROUND** wire from fixture to supply ground.
4. Connect the purple fixture lead to the **(V+) DIM** lead.
5. Connect the pink fixture lead to the **(V-) DIM** lead.

NOTE: Do not connect DIM V+ (purple)/ DIM V- (pink) to line voltage or supply ground.

Fig. 20

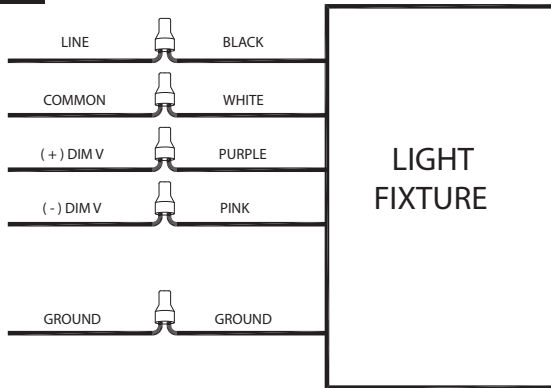

0-10V DIMMABLE WIRING

(Suitable for X22-80, X22-150)

Universal voltage driver permits operation at 120V through 277V, 50 or 60 Hz. For 0-10V dimming follow the wiring directions as shown in Fig. 21.

1. Connect the black fixture lead to the **LINE** supply lead.
2. Connect the white fixture lead to the **COMMON** supply lead.
3. Connect the **GROUND** wire from fixture to supply ground.
4. Connect the purple fixture lead to the **(V+) DIM** lead.
5. Connect the pink fixture lead to the **(V-) DIM** lead.
6. Cap the yellow fixture lead, if present. Do NOT connect.

NOTE: Do not connect DIM V+ (purple)/ DIM V- (pink) to line voltage or supply ground.

Fig. 21

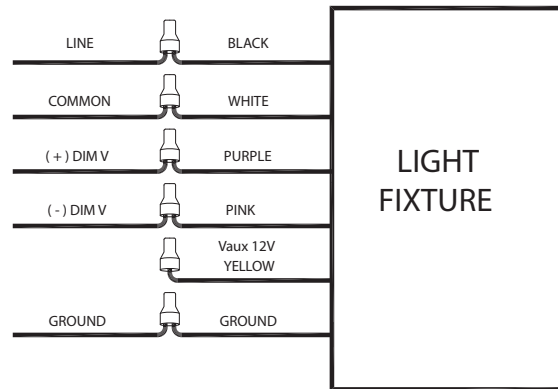

CLEANING & MAINTENANCE

CAUTION: Be sure fixture temperature is cool enough to touch. Do not clean or maintain while fixture is energized.

1. Do not open fixture to clean the LED. Do not touch the LED.
2. Clean glass lens with non-abrasive glass cleaning solution.

TROUBLESHOOTING

1. Check that the line voltage at the fixture is correct. Refer to wiring directions.
2. Is the fixture grounded properly?

Note: These instructions do not cover all details or variations in equipment nor do they provide for every possible situation during installation, operation or maintenance.

RAB®

Easy Answers

rablighting.com
Visit our website for product info

Tech Help Line
Call our experts: 888 722-1000

e-mail
Answered promptly - sales@rablighting.com

Free Lighting Layouts
Answered online or by request

© 2023 RAB LIGHTING INC.
X22 20/35/60/80/150W-1023
P-100618

RAB WARRANTY: RAB's warranty is subject to all terms and conditions found at rablighting.com/warranty.