

INSTRUCTIONS

BEAM™ FIELD ADJUSTABLE TRACK LIGHT INSTALLATION



RAB Lighting is committed to creating high-quality, affordable, well-designed and energy-efficient LED lighting and controls that make it easy for electricians to install and end users to save energy. We'd love to hear your comments. Please call the Marketing Department at 888-RAB-1000 or email: marketing@rablighting.com

**** DON'T TOSS IT—RECYCLE IT! MAKE THE SUSTAINABLE CHOICE BY RECYCLING THIS FIXTURE AT END OF LIFE WITH A LICENSED RECYCLING PROVIDER. ****



TKBEAM 2ft



TKBEAM 4ft

IMPORTANT

READ CAREFULLY BEFORE INSTALLING FIXTURE. RETAIN THESE INSTRUCTIONS FOR FUTURE REFERENCE.

RAB fixtures must be wired in accordance with the National Electrical Code and all applicable local codes. Proper grounding is required for safety. THIS PRODUCT MUST BE INSTALLED IN ACCORDANCE WITH THE APPLICABLE INSTALLATION CODE BY A PERSON FAMILIAR WITH THE CONSTRUCTION AND OPERATION OF THE PRODUCT AND THE HAZARDS INVOLVED.

WARNING:

- Make certain power is OFF before installing or maintaining fixture. No user serviceable parts inside.
- Fixture is suitable for dry location.
- Fixture must be mounted a minimum of 4ft above ground level.
- Fixtures are 120V ONLY.
- **Power/Color Temperature should be selected prior to installation. Do NOT switch settings with power on.**

TRACK MOUNT INSTALLATION

1. Secure the track system onto the ceiling (Fig. 1).

Fig: 1

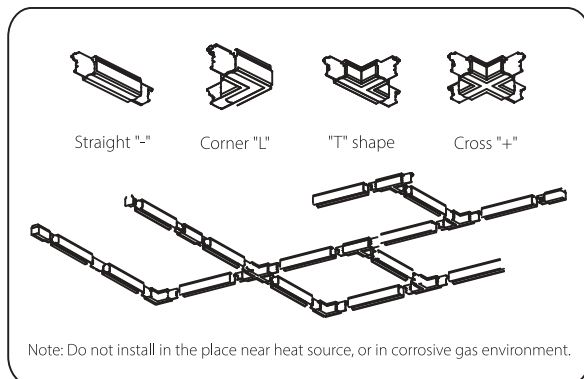
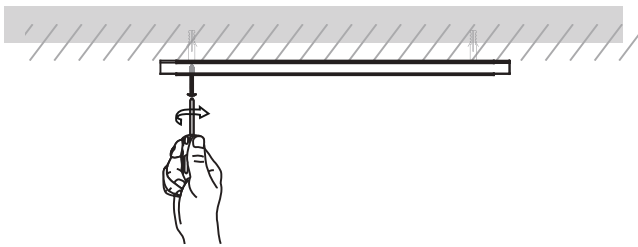

2. Manually select preferred Color Temperature (CCT) and/or Power (W) prior to mounting, see Fig. 6. Verify that the Track Adapter is in the Unlocked Position (Fig. 2).

Fig: 2

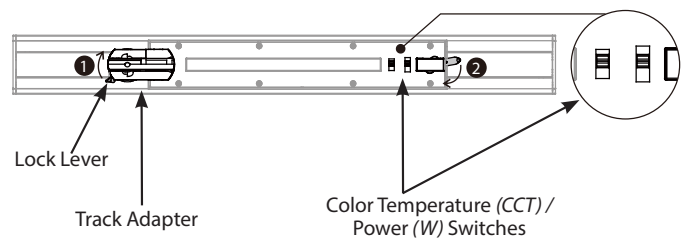

3. Insert the fixture's Track Adapter into the track system and secure into place with the Lock Lever (Fig. 3).

Fig: 3

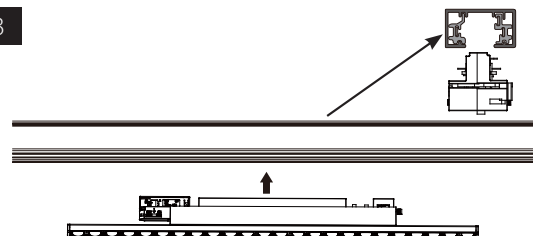

INSTRUCTIONS

BEAM™ FIELD ADJUSTABLE TRACK LIGHT INSTALLATION



RAB Lighting is committed to creating high-quality, affordable, well-designed and energy-efficient LED lighting and controls that make it easy for electricians to install and end users to save energy. We'd love to hear your comments. Please call the Marketing Department at 888-RAB-1000 or email: marketing@rablighting.com

**** DON'T TOSS IT—RECYCLE IT! MAKE THE SUSTAINABLE CHOICE BY RECYCLING THIS FIXTURE AT END OF LIFE WITH A LICENSED RECYCLING PROVIDER. ****

TRACK MOUNT INSTALLATION (cont'd)

4. Lock the **Track Adapter** into track rail and secure (Fig. 4).

Fig: 4

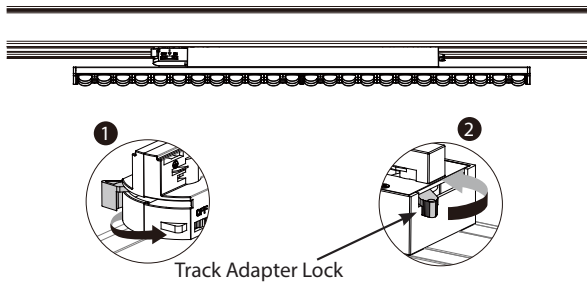

5. Make sure that the **On/Off** switch is set to **ON** (Fig. 5).

Fig: 5

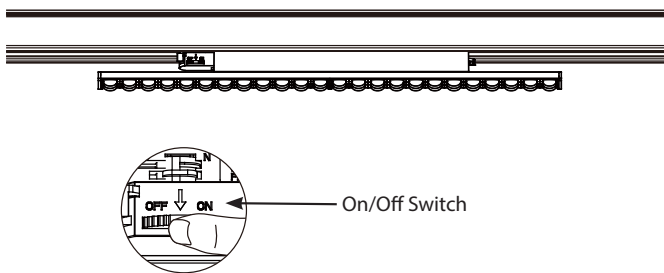

CLEANING & MAINTENANCE

CAUTION: Be sure fixture temperature is cool enough to touch. Do not clean or maintain while fixture is energized.

1. Clean acrylic lens with non-abrasive cleaning solution.
2. Do not open the fixture to clean the LEDs. Do not touch the LEDs.

FIELD ADJUSTMENT

Color Temperature (CCT) Selection:

This product is equipped with 2700/3000K/3500K/4000K/5000K (CCT) Color Temperature selection.

Power (Wattage) Selection:

This product is equipped with power output selection.

TKBEAM2 30/22/15W

TKBEAM4 60/50/40W

Follow instructions below to change **Color Temperature (CCT)** and/or **Power (W)** from factory settings.

Factory Settings:

TKBEAM2 30W / 4000K

TKBEAM4 60W / 4000K

1. Locate the **Selector Switches** as shown in Fig. 6.
2. Select **Color Temperature** and/or **Power** by sliding the respective switch to the desired setting.

Fig: 6

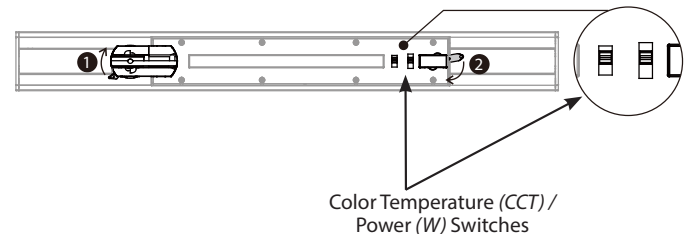

TROUBLESHOOTING

1. Check that the line voltage at the fixture is correct. Refer to wiring directions.
2. Is the fixture grounded properly?

Note: These instructions do not cover all details or variations in equipment nor do they provide for every possible situation during installation, operation or maintenance.



Easy Answers

© 2026 RAB LIGHTING Inc.

rablighting.com
Visit our website for product info

Tech Help Line
Call our experts: 888 722-1000

e-mail
Answered promptly - tech@rablighting.com

Free Lighting Layouts
Answered online or by request

TKBEAM - Track Light - 0526
P-102750

RAB WARRANTY: RAB's warranty is subject to all terms and conditions found at rablighting.com/warranty.