

INSTRUCTIONS

3"/4" Premium Downlight FA



RAB Lighting is committed to creating high-quality, affordable, well-designed and energy-efficient LED lighting and controls that make it easy for electricians to install and end users to save energy. We'd love to hear your comments. Please call the Marketing Department at 888-RAB-1000 or email: marketing@rablighting.com

C3R5.5/7/8.59FAUNVW
C3R5.5/7/8.59FAUNVM
C4R8/10/119FAUNVW
C4R8/10/119FAUNVM



IMPORTANT

READ CAREFULLY BEFORE INSTALLING FIXTURE. RETAIN THESE INSTRUCTIONS FOR FUTURE REFERENCE.

RAB fixtures must be wired in accordance with the National Electrical Code and all applicable local codes. Proper grounding is required for safety. THIS PRODUCT MUST BE INSTALLED IN ACCORDANCE WITH THE APPLICABLE INSTALLATION CODE BY A PERSON FAMILIAR WITH THE CONSTRUCTION AND OPERATION OF THE PRODUCT AND THE HAZARDS INVOLVED.

WARNINGS:

- Risk of electrical shock. Disconnect power at fuse or circuit breaker before installing or servicing.
- To prevent early lamp failure, lamp should only be installed in operating environments ranging between -30°C and +40°C (-22°F and +104°F).
- No user serviceable parts inside. To avoid electrical shock do not disassemble product.
- Risk of fire or electric shock, LED Retrofit Kit installation requires knowledge of luminaires electrical systems. If not qualified, do not attempt installation. Contact a qualified electrician.
- Risk of fire or electric shock, Install this kit only in luminaires that have the construction features and min dimensions shown in below and where the input rating of the retrofit kit does not exceed the input rating of the luminaire.
- Do not make or alter any open holes in an enclosure of wiring or electrical components during kit installation
- To prevent wiring damage or abrasion, do not expose wiring to edges of sheet metal or other sharp objects.
- Installers should not disconnect existing wires from lampholder terminals to make new connections at lampholder terminals, Instead installers should cut existing lampholder leads away from the lampholder and make new electrical connections to lampholder lead wires by employing applicable connectors.
- This retrofit kit is accepted as a component of a luminaire where the suitability of the combination shall be determined by authorities having jurisdiction. Product must be installed by a qualified electrician in accordance with the applicable and appropriate electrical codes. The installation guide does not supersede local national regulations for electrical installations.
- This device is not intended for use with emergency exits.
- Caution - risk of fire. Consult a qualified electrician to ensure correct branch circuit conductor.
- Min.90°C supply conductors.
- Installers should examine all parts that are not intended to be replaced by the retrofit kit for damage and replace any damaged parts prior to installation of the retrofit kit.

WHAT'S IN THE BOX

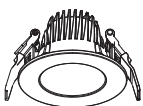

Downlight (1)



Screw (2)



Lumi Sticker (1)



Template (1)

MIN.LUMINAIRE DIMENSION

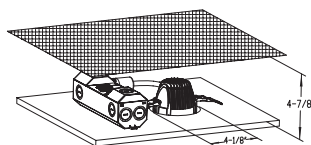
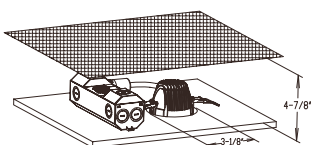

TOOLS NEEDED

This LED Recessed Kit requires very few tools for installation. A screwdriver and a pair of wirecutters will help to install the downlight to a JBox or housing.

OPTIONAL ACCESSORIES

Plate

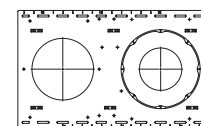

DLPLATE/T
New construction or remodel plate for T-grid ceilings

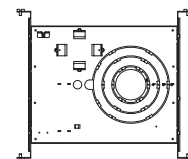

DLPLATE/C3468R/NB
Mounting plate with nailer bar

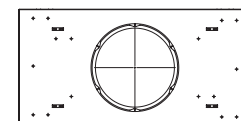

DLPLATE/SJ
New construction plate for Stud/Joist

INSTRUCTIONS

3"/4" Premium Downlight FA



RAB Lighting is committed to creating high-quality, affordable, well-designed and energy-efficient LED lighting and controls that make it easy for electricians to install and end users to save energy. We'd love to hear your comments. Please call the Marketing Department at 888-RAB-1000 or email: marketing@rablighting.com

INSTALLATION WITH EXISTING FRAME

1. Shut power OFF to the fixture.
2. Remove CFL, Incandescent or HID lamp. (Fig.1)

Fig: 1

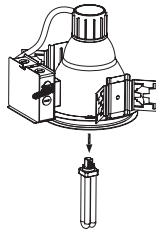

3. Remove reflector from rough-in (mounting frame). (Fig.2)

Fig: 2

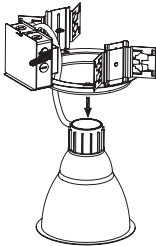

4. Remove socket assembly from reflector. (Fig.3)

Fig: 3

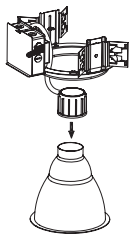

5. Remove J-Box metal plate with existing lamp ballast. Do not dispose. Disconnect all wires from the ballast. (Fig.4)

Fig: 4

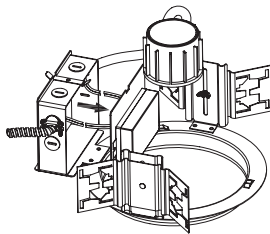

6. Remove the existing lamp metal conduit (MC) cable from the J-Box. (Fig.5)

Fig: 5

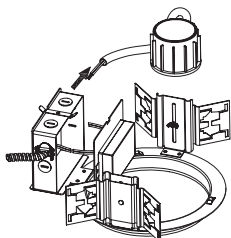

INSTALLATION WITH EXISTING FRAME (cont'd)

7. Select desired lumen output and CCT. (Fig.6)

Fig: 6

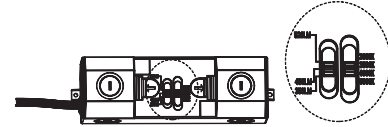

8. Remove cover plate from the external driver box of the LED retrofit kit. (Fig.7)

Fig: 7

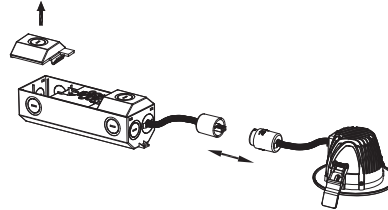

9. Fasten the MC cable to the driver case. Push each wire into its corresponding connector. (Per UL8750 Clause 7.12.1, the product design is CLASS 2 without risk of electric shock, no need ground wire) (Fig.8)

Fig: 8

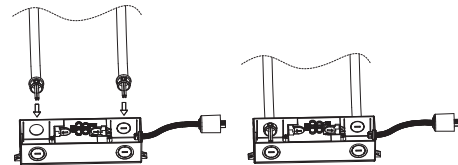

10. Put back the cover plate on the driver box. (Fig.9)

Fig: 9

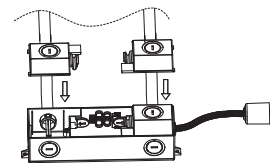

11. Connect the DL with the external driver by engaging the connector on the cable. (Fig.10)

Fig: 10

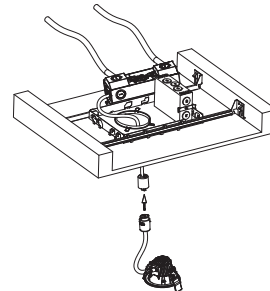

12. Install the LED kit by lifting both retention tabs upward. (Fig.11)

Fig: 11

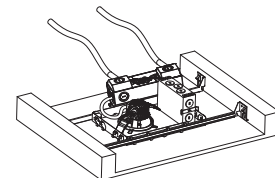

12. Turn power ON and start saving \$\$.

Note: These instructions do not cover all details or variations in equipment nor do they provide for every possible situation during installation, operation or maintenance.

INSTRUCTIONS

3"/4" Premium Downlight FA



RAB Lighting is committed to creating high-quality, affordable, well-designed and energy-efficient LED lighting and controls that make it easy for electricians to install and end users to save energy. We'd love to hear your comments. Please call the Marketing Department at 888-RAB-1000 or email: marketing@rablighting.com

INSTALLATION WITHOUT EXISTING FRAME

1. Use template inside box to cut hole in ceiling. (Fig.11)

Fig: 11

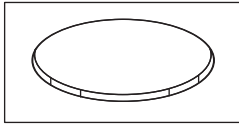

2. Select desired lumen output and CCT. (Fig.12)

Fig: 12

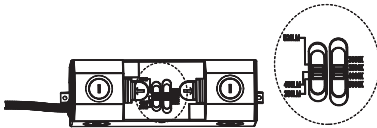

3. Fasten the MC cable to the driver case. Push each wire into its corresponding connector. (Per UL8750 Clause 7.12.1, the product design is CLASS 2 without risk of electric shock, no need ground wire.) (Fig.13)

Fig: 13

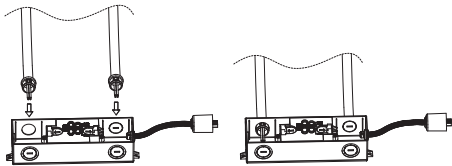

4. Put back the cover plate on the driver box. (Fig.14)

Fig: 14

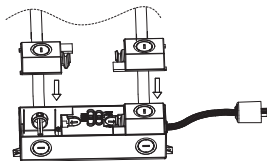

5. Connect the DL with the external driver by engaging the connector on the cable. (Fig.15)

Fig: 15

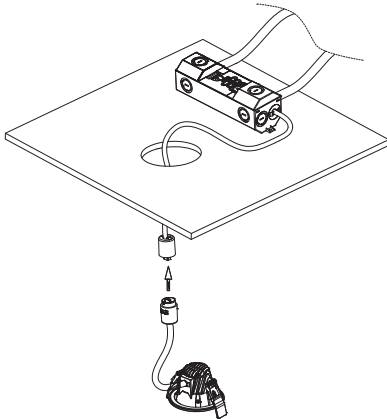

INSTALLATION WITHOUT EXISTING FRAME (cont'd)

6. Install the LED kit by lifting both retention tabs upward. (Fig.16)

Fig: 16

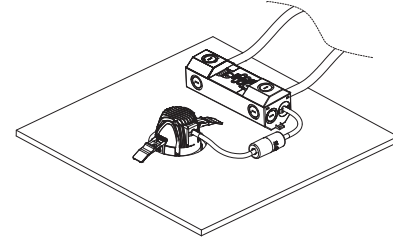

7. Push the kit until it sits flush against the ceiling. (Fig.17)

Fig: 17

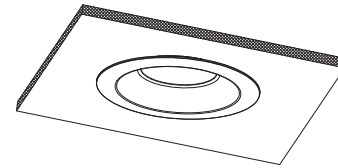

DIMENSIONAL DRAWINGS

C3R5.5/7/8.59FAUNVW
C3R5.5/7/8.59FAUNVM

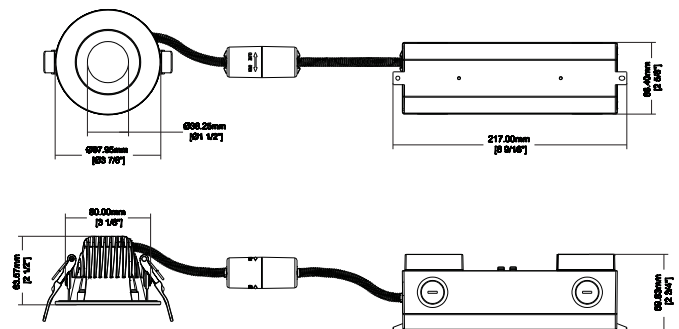

C4R8/10/119FAUNVW
C4R8/10/119FAUNVM

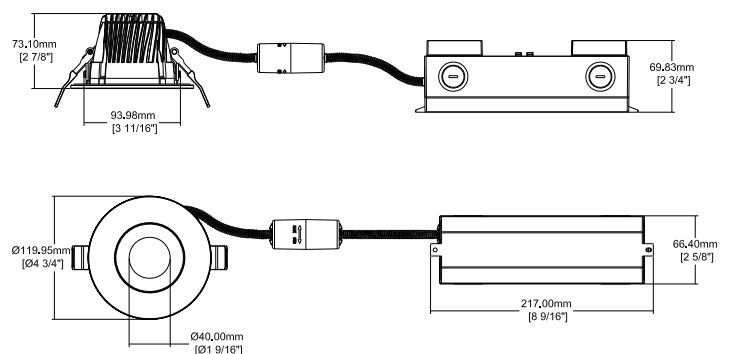

INSTRUCTIONS

6"/8" Premium Downlight FA



RAB Lighting is committed to creating high-quality, affordable, well-designed and energy-efficient LED lighting and controls that make it easy for electricians to install and end users to save energy. We'd love to hear your comments. Please call the Marketing Department at 888-RAB-1000 or email: marketing@rablighting.com

C6R12/18/249FAUNVW
C6R12/18/249FAUNVM
C8R34/46/599FAUNVW
C8R34/46/599FAUNVM



IMPORTANT

READ CAREFULLY BEFORE INSTALLING FIXTURE. RETAIN THESE INSTRUCTIONS FOR FUTURE REFERENCE.

RAB fixtures must be wired in accordance with the National Electrical Code and all applicable local codes. Proper grounding is required for safety. THIS PRODUCT MUST BE INSTALLED IN ACCORDANCE WITH THE APPLICABLE INSTALLATION CODE BY A PERSON FAMILIAR WITH THE CONSTRUCTION AND OPERATION OF THE PRODUCT AND THE HAZARDS INVOLVED.

WARNINGS:

- Risk of electrical shock. Disconnect power at fuse or circuit breaker before installing or servicing.
- To prevent early lamp failure, lamp should only be installed in operating environments ranging between -30°C and $+40^{\circ}\text{C}$ (-22°F and $+104^{\circ}\text{F}$).
- No user serviceable parts inside. To avoid electrical shock do not disassemble product.
- Risk of fire or electric shock, LED Retrofit Kit installation requires knowledge of luminaires electrical systems. If not qualified, do not attempt installation. Contact a qualified electrician.
- Risk of fire or electric shock, Install this kit only in luminaires that have the construction features and min dimensions shown in below and where the input rating of the retrofit kit does not exceed the input rating of the luminaire.
- Do not make or alter any open holes in an enclosure of wiring or electrical components during kit installation
- To prevent wiring damage or abrasion, do not expose wiring to edges of sheet metal or other sharp objects.
- Installers should not disconnect existing wires from lampholder terminals to make new connections at lampholder terminals, Instead installers should cut existing lampholder leads away from the lampholder and make new electrical connections to lampholder lead wires by employing applicable connectors.
- This retrofit kit is accepted as a component of a luminaire where the suitability of the combination shall be determined by authorities having jurisdiction. Product must be installed by a qualified electrician in accordance with the applicable and appropriate electrical codes. The installation guide does not supersede local national regulations for electrical installations.
- This device is not intended for use with emergency exits.
- Caution - risk of fire. Consult a qualified electrician to ensure correct branch circuit conductor.
- Min. 90°C supply conductors.
- Installers should examine all parts that are not intended to be replaced by the retrofit kit for damage and replace any damaged parts prior to installation of the retrofit kit.

WHAT'S IN THE BOX



Downlight (1)



Screw (2)



Lumi Sticker (1)



Template (1)

MIN. LUMINAIRE DIMENSION

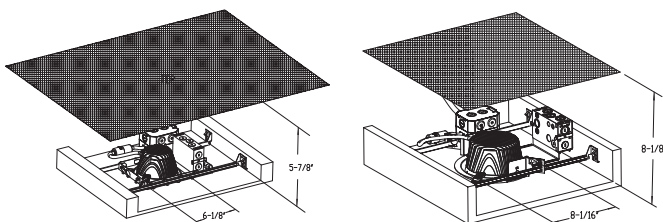

TOOLS NEEDED

This LED Recessed Kit requires very few tools for installation. A screwdriver and a pair of wirecutters will help to install the downlight to a JBox or housing.

OPTIONAL ACCESSORIES

Plate

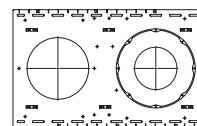

DLPLATE/T
New construction or remodel plate for T-grid ceilings

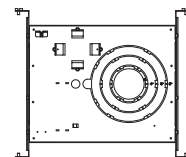

DLPLATE/C3468R/NB
Mounting plate with nailer bar

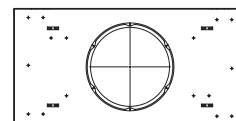

DLPLATE/SJ
New construction plate for Stud/Joist

INSTRUCTIONS

6"/8" Premium Downlight FA



RAB Lighting is committed to creating high-quality, affordable, well-designed and energy-efficient LED lighting and controls that make it easy for electricians to install and end users to save energy. We'd love to hear your comments. Please call the Marketing Department at 888-RAB-1000 or email: marketing@rablighting.com

INSTALLATION WITH EXISTING FRAME

1. Shut power OFF to the fixture.
2. Remove CFL, Incandescent or HID lamp. (Fig.1)

Fig: 1

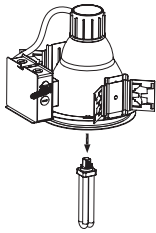

3. Remove reflector from rough-in(mounting frame). (Fig.2)

Fig: 2

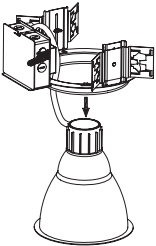

4. Remove socket assembly from reflector. (Fig.3)

Fig: 3

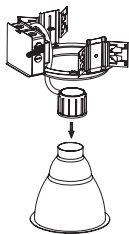

5. Remove J-Box metal plate with existing lamp ballast. Do not dispose. Disconnect all wires from the ballast. (Fig.4)

Fig: 4

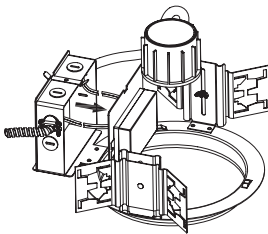

6. Remove the existing lamp metal conduit (MC) cable from the J-Box. (Fig.5)

Fig: 5

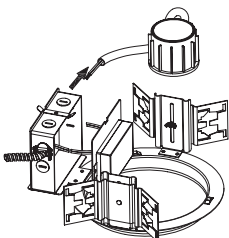

INSTALLATION WITH EXISTING FRAME (cont'd)

7. Select desired lumen output and CCT. (Fig.6)

Fig: 6

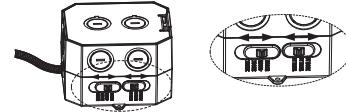

8. Remove cover plate from the external driver box of the LED retrofit kit. (Fig.7)

Fig: 7

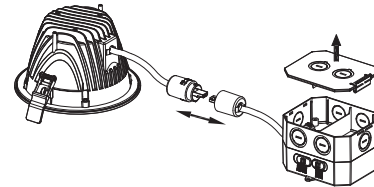

9. Fasten the MC cable to the driver case. Push each wire into its corresponding connector. (Fig.8)
(Per UL8750 Clause 7.12.1, the product design is CLASS 2 without risk of electric shock, no need ground wire.)

Fig: 8

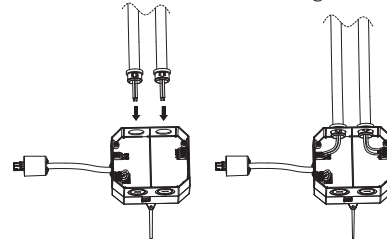

10. Put back the cover plate on the driver box. (Fig.9)

Fig: 9

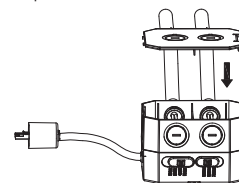

11. Connect the DL with the external driver by engaging the connector on the cable. (Fig.10)

Fig: 10

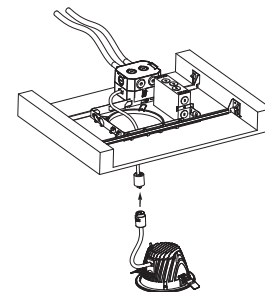

12. Install the LED kit by lifting both retention tabs upward. (Fig.11)

Fig: 11

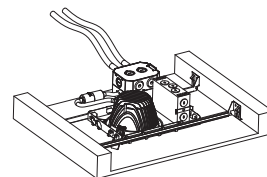

12. Turn power ON and start saving \$\$.

Note: These instructions do not cover all details or variations in equipment nor do they provide for every possible situation during installation, operation or maintenance.

INSTRUCTIONS

6"/8" Premium Downlight FA



RAB Lighting is committed to creating high-quality, affordable, well-designed and energy-efficient LED lighting and controls that make it easy for electricians to install and end users to save energy. We'd love to hear your comments. Please call the Marketing Department at 888-RAB-1000 or email: marketing@rablighting.com

INSTALLATION WITH EMBB

1. Select desired lumen output and CCT. (Fig.12)

Fig: 12

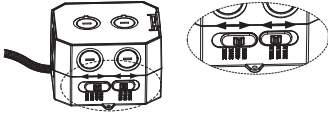

2. Remove cover plate from the external driver box of the LED retrofit kit. With a small flat screw driver or other tool, push on the connector buttons to release the jumper wires for LED -, LED +, DRV + and DRV -. Pull the wires out and discard. (Fig.13)

Fig: 13

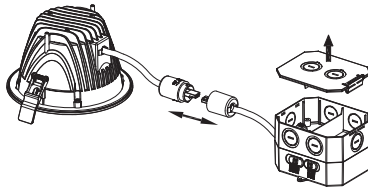

3. Take the Emergency Battery Backup System (EMBB), snap-in the Flex A and Flex B MC cable into the driver box as indicated in the diagram below. (Fig.14)

Fig: 14

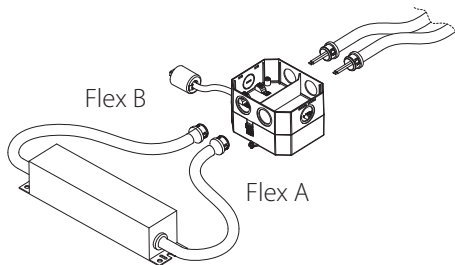

4. A test switch is provided with the EMBB. If required for your installation, install it with the appropriate hardware. A suggested installation is shown here. The conduit and box for the test switch are not provided. (Fig.15)

Fig: 15

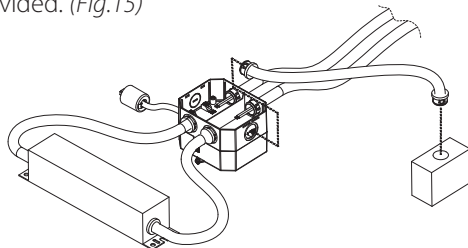

INSTALLATION WITH EMBB

5. In the driver box, use wire nuts and connector to do the wire connections as illustrated in the diagram below. If the test switch is not in use, cap the purple (Test +) and brown (Test -) wire from the EMBB with wire nuts. Make sure EMBB is grounded. (Fig.16)

Fig: 16

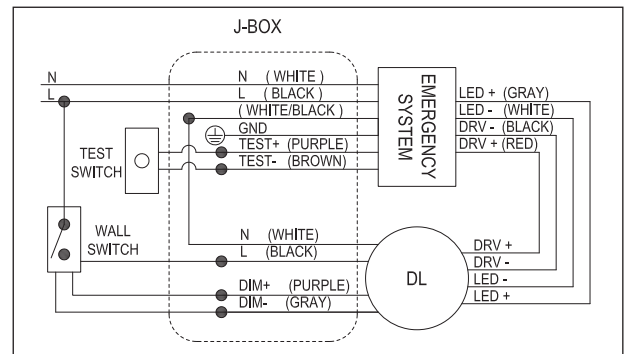

6. Put back the cover plate on the driver box. (Fig.17)

Fig: 17

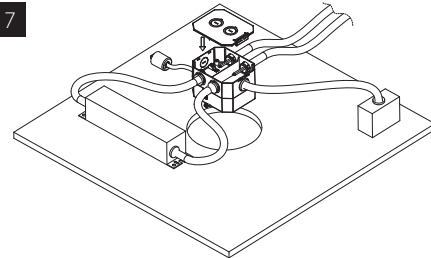

7. Install the retrofit kit in the rough-in by lifting upward both retention tabs. Push the kit until it sits flush against the ceiling. (Fig.18)

Fig: 18

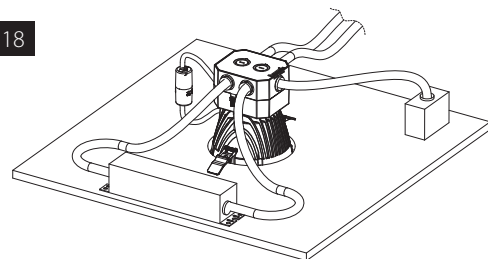

8. Turn power ON and start saving \$\$.

Note: These instructions do not cover all details or variations in equipment nor do they provide for every possible situation during installation, operation or maintenance.

INSTRUCTIONS

6"/8" Premium Downlight FA



RAB Lighting is committed to creating high-quality, affordable, well-designed and energy-efficient LED lighting and controls that make it easy for electricians to install and end users to save energy. We'd love to hear your comments. Please call the Marketing Department at 888-RAB-1000 or email: marketing@rablighting.com

INSTALLATION WITHOUT EXISTING FRAME

1. Use template inside box to cut hole in ceiling. (Fig.19)

Fig: 19

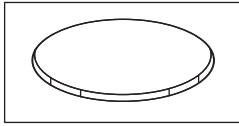

2. Select desired lumen output and CCT. (Fig.20)

Fig: 20

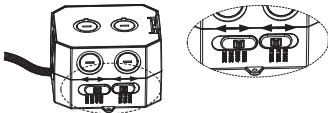

3. Fasten the MC cable to the driver case. Push each wire into its corresponding connector. (Fig.21)
(Per UL8750 Clause 7.12.1, the product design is CLASS 2 without risk of electric shock, no need ground wire.)

Fig: 21

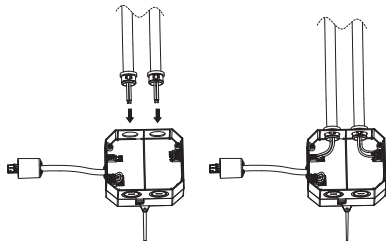

4. Put back the cover plate on the driver box. (Fig.22)

Fig: 22

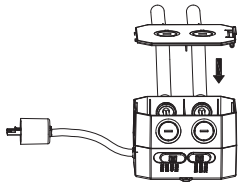

5. Connect the DL with the external driver by engaging the connector on the cable. (Fig.23)

Fig: 23

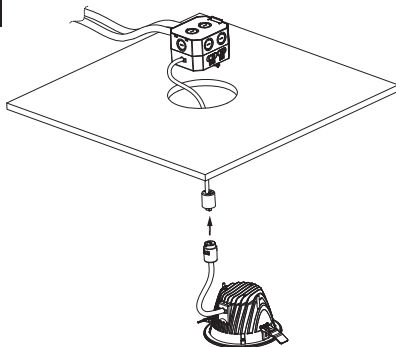

INSTALLATION WITHOUT EXISTING FRAME (cont'd)

6. Install the LED kit by lifting both retention tabs upward. (Fig.24)

Fig: 24

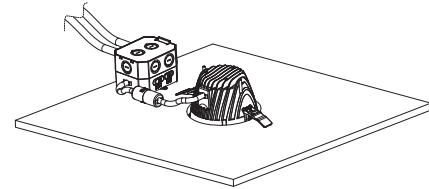

7. Push the kit until it sits flush against the ceiling. (Fig.25)

Fig: 25

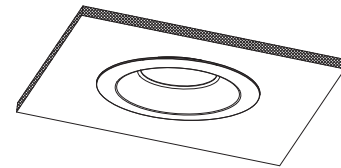

DIMENSIONAL DRAWINGS

C6R12/18/249FAUNVW C6R12/18/249FAUNVM

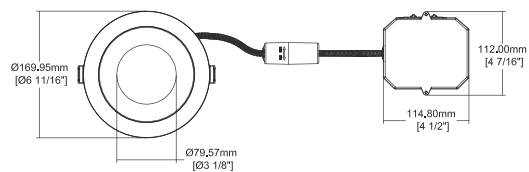
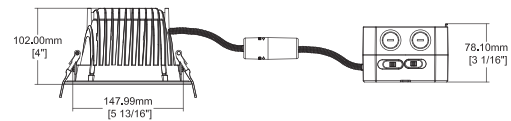

C8R34/46/599FAUNVW C8R34/46/599FAUNVM

