

Welcome

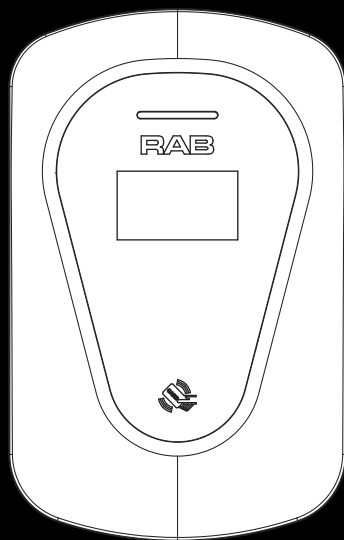

EVC48

Charging Station

INSTALLATION INSTRUCTIONS

RAB[®]

1. Important Safety Instructions

Please read all Important Safety Instructions as well as charging instructions in your vehicle owner's manual before attempting to charge your electric vehicle. Failure to do so can result in death or severe injury. Save this user manual for future reference. There are many safety features built into the charger. Read all the safety information and warnings in this manual to avoid any risks or hazards and risks associated with using this charger.

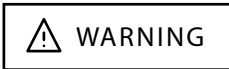

When using electric products, basic precautions should always be followed, including the following.

- a) Read all the instructions before using this product.
- b) This device should be supervised when used around children.
- c) Do not put fingers into the electric vehicle connector.
- d) Do not use this product if the flexible power cable or EV cable is frayed, has broken insulation, or any other signs of damage.
- e) Do not use this product if the enclosure or the EV connector is broken, cracked, open, or shows any other indication of damage.

f) **WARNING**

GROUNDING INSTRUCTIONS

This product must be connected to a grounded, metal, permanent wiring system, or an equipment-grounding conductor must be run with the circuit conductors and connected to the equipment grounding terminal or lead on the product.

- g) Risk of electric shock.
- h) Save these instructions.

2. FCC & IC Application

This device complies with Part 15 of the FCC Rules / Industry Canada licence-exempt RSS standard(s). Operation is subject to the following two conditions: (1) this device may not cause harmful interference, and (2) this device must accept any interference received, including interference that may cause undesired operation.

Changes or modifications not expressly approved by the party responsible for compliance could void the user's authority to operate the equipment.

This equipment has been tested and found to comply with the limits for a Class A digital device, pursuant to part 15 of the FCC Rules. These limits are designed to provide reasonable protection against harmful interference when the equipment is operated in a commercial environment. This equipment generates, uses, and can radiate radio frequency energy and, if not installed and used in accordance with the instruction manual, may cause harmful interference to radio communications. Operation of this equipment in a residential area is likely to cause harmful interference in which case the user will be required to correct the interference at his own expense.

MPE Requirements

To satisfy FCC / IC RF exposure requirements, a separation distance of 20 cm or more should be maintained between the antenna of this device and persons during device operation.

To ensure compliance, operations at closer than this distance is not recommended.

3. Interface

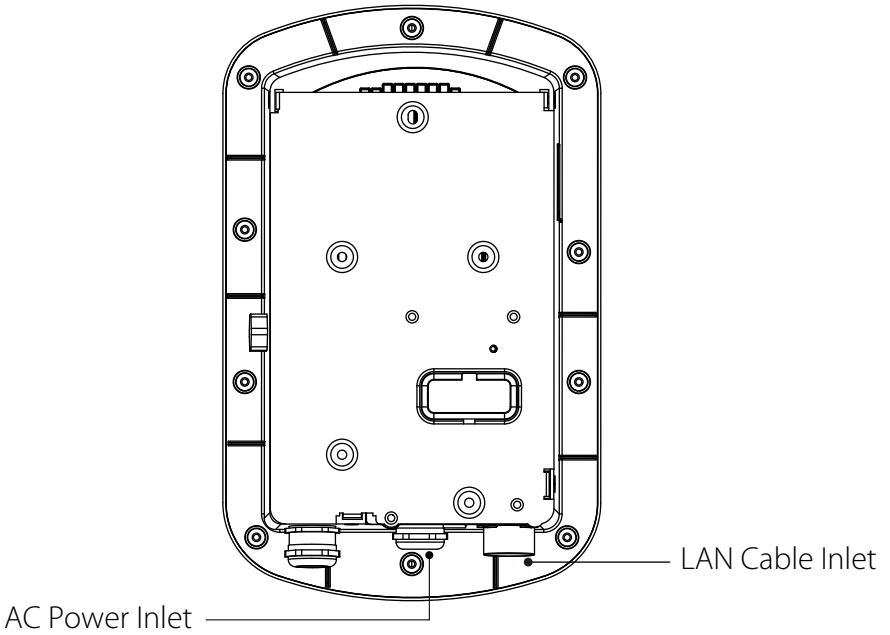
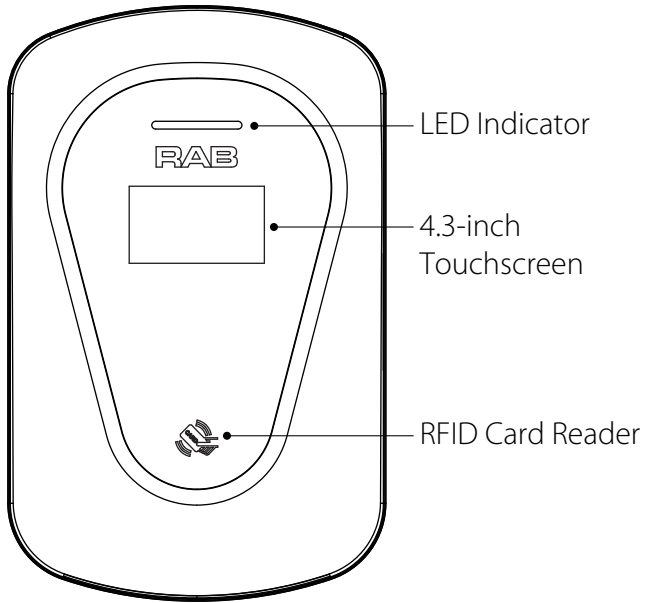

4. Dimensions

Charger

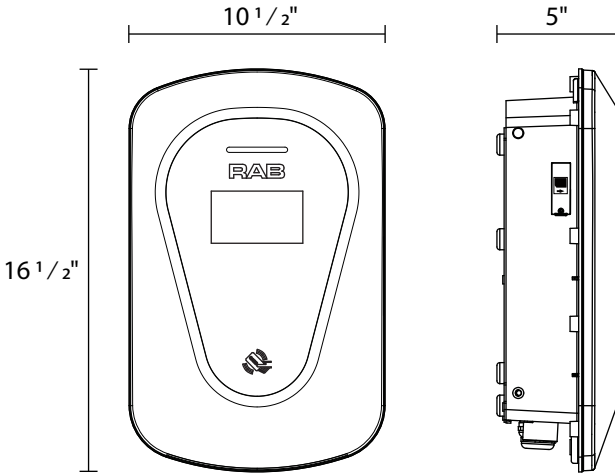

Wall-Mount Bracket

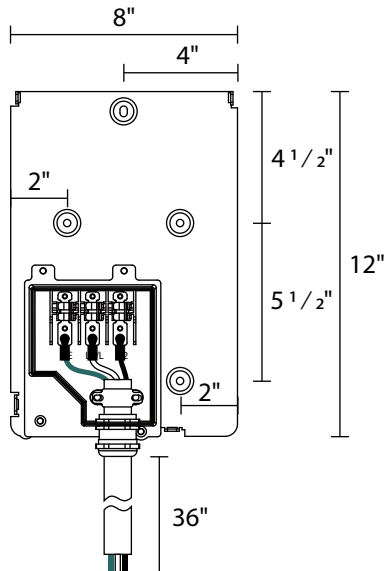

5. Equipment Specifications

Maximum Power	11.5KW
Input Voltage	200-240VAC / L-L/L-N Single phase
Output Voltage	200-240VAC / L-L/L-N Single phase
Input Current	48A
Output Current	48A
Input Frequency	60Hz
Charge Mode	Plug & Play or Scan QR code
Operating Temperature	-30°C to +50°C (-22°F to 122°F)
Relative Humidity	≤90%
Enclosure Rating	Type 4
Impact Resistance	IK08
Output Protection	Leakage protection, over-voltage protection, over current protection, under-voltage protection, automatic full charge protection, control pilot fault protection, short circuit protection, over temperature protection.
Input Protection	Over-voltage protection, over current protection, under-voltage protection, short circuit protection, over temperature protection.
Installation Mode	Wall-mounted
Touchscreen	4.3 inch
Cable Length	18 ft
Dimension	16 1/2 x 10 1/2 x 5 inch
Operating Environment	Indoor & Outdoor
Application	Commercial charging
Connectivity	BLE, WIFI, Ethernet, 4G
4G and WIFI operate	2.4GHz band
Input Cable	3ft (<i>hardwire</i>)
Output Interface	SAE J1772 AC
Certification Standards	UL 2594: 2022 Ed.3 Clause, CSA C22.2#280:2022 Ed.3, UL 2231-2:2012 Ed.2+R:15Dec2020 Clause, UL 1998:2013 Ed.3+R:24Sep2018 Clause, UL 991:2004 Ed.3+R:09Jun2010: Clause, UL 50E: 2020 Ed.3 Clause
Altitude	≤6561.68 ft
Net Weight	20.7 lbs (<i>Includes charging connector and output cable</i>)

6. LED Indicator Description



Bluetooth Connected / Disconnected
Green light flashes, 0.3s on, 0.3s off, lasts 10s



Network Disconnected
Green light and red right alternate every 1 second



Available
Green light always on



Preparing
Green light flashes, 2s on, 2s off



Charging
The green light gradually brightens from dim, then gradually dims from bright.



Finishing
The green light gradually brightens from dim.



Electric leakage

Red light flashes, 2 seconds on, 2 seconds off



Ground fault

Red light flashes, 4 seconds on, 4 seconds off



Power meter malfunction

Red light flashes, 6 seconds on, 6 seconds off



Other errors (*overvoltage, overcurrent, undervoltage*)

Red light always on

Note: Contact RAB technical support for guidance and a licensed electrician to service the electric vehicle charger.

7. Installation Instructions

7a. Contractor Safety Guide

- This guide aims to provide a safe work environment for everyone, including participants, installation and demolition crews, contractors, and subcontractors.
- Ultimately, it is the responsibility of contractors to ensure the safety and safe work practices of their employees and subcontractors who may be working at the site on their behalf.
- This guide serves as a simple reference for basic safety rules. It does not cover every safety standard but is designed to supplement the knowledge of participants, contractors, and subcontractors.
- Contractors, subcontractors and employees should cooperate with their employers and other persons in complying with safety regulations and instructions.
- In particular, employees should:
 - Obtain the qualified authorization of the responsible unit in the construction area.
 - Work safely.
 - Not do anything to endanger themselves or other persons.
 - Use personal protective equipment as required and take reasonable care of when it is not in use.
 - Report unsafe activities immediately to supervisors or the responsible person in control of the workplace, and Report all accidents and dangerous occurrences to the supervisor immediately after they happen.

1- Reference standards



Adhere to the following codes:

- NFPA-70E -2021 Sec 110.3 (*Electrical Safety in the Workplace*)
- NFPA-70E -2021 Sec 130.4 (*Shock Risk Assessment*)
- NFPA-70E -2021 Sec 130.5 (*Arc Flash Risk Assessment*)

2- Requirements for workplace conditions



- Set up suitable fencing to isolate the construction area from outside
- Close and secure all entrances when the site is unattended
- Hang warning notices nearby which show the following information: warning icon and phone number of people in charge
- Install sufficient lighting fixtures

3- Cleaning up



- Keep work areas (*including accessways*) free from debris and obstructions
- Keep ground surfaces tidy and flat, to avoid people tripping or being hurt by tools or other objects
- Stack and store equipment and materials in a tidy and stable manner
- Regularly clean up and dispose of waste
- Remove all surplus materials and equipment after completion of work

4- Fire hazards



- Beware of flammable materials and goods. Keep them away from work areas

5- Protection against high temperatures on the worksite



- Erect a sunshade or shed to shelter workers from the heat and sun
- Set up cooling equipment, such as exhaust fans
- Make water dispensers available
- Provide suitable protective clothing such as hat, sunglasses and long sleeves to protect workers from heat stroke and UV rays

6- Inclement weather



- Secure all scaffoldings, temporary structures, equipment, and loose materials
- Check and implement SOP to ensure disconnection of gas supplies, electrical circuits and equipment
- Inspect worksites to ensure protection against ingress of water or dust
- Inspect the drainage system for blockages and remove if found
- Stop all outdoor works except for emergency works

7- Ladders



- Only use ladders that meet local safety regulations
- When working at height, it is recommended to use platforms instead of ladders
- If using a platform is not practicable, a supervisor should assess the potential risk and provide safety protection equipment for workers
- use non-conductive ladders made of glass-fiber or reinforced plastic when carrying out electrical work
- Assign assistants to provide support when working on ladders
- Check all ladders for broken rungs or other defects before use and periodically
- Fully open stepladders when in use
- Do not overreach when working on a ladder
- Beware of overload restrictions

Country	Standards
USA	ANSI A 14.1, ANSI A 14.2, ANSI A 14.5

8- Working at height

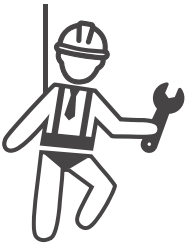

- Avoid working at height by using alternative tools and methods as far as practicable
- It is strongly recommended to build suitable scaffolding or work platforms
- Provide fall arrest systems for workers if it is impracticable to use working platforms
- Secure all materials and tools to prevent them falling from height

9- Lifting operations



- Have lifting gear and apparatus regularly inspected and tested by qualified persons
- Isolate and cordon off lifting areas to keep out non-construction personnel
- Ensure that lifting routes do not cross buildings or people, and avoid collision with objects
- Do not exceed safe working load limits

10- For on-site workers



- Plan all work
- Turn off power (*work with live parts de-energized whenever possible*)
- LOTO (*Lock Out, Tag Out*)
- Live electrical work permit (*input terminals with HV after door open*)
- Use personal protective equipment (*PPE*)
- Safe workplace conditions and space
- Adhere to other occupational health, safety and security codes, such as those published by OSHA

7b. Safety Requirements

- Read this user manual thoroughly and ensure compliance with all local building and electrical codes before installation. A qualified electrician must install the AC charger in accordance with this manual and local regulations.
- Use appropriate protective equipment when connecting to the main power distribution system.
- A Type C 60A circuit breaker must be installed in the upstream AC distribution panel.
- Disconnect switches for all ungrounded AC input conductors must be installed by others, complying with the National Electrical Code (*ANSI/NFPA 70*).
- Verify proper grounding:
 - The Wall Connector's ground must bond to the upstream power supply
 - Inspect all connections (*terminal box, electrical panels, and wiring*)
 - For residential systems: Confirm neutral-ground bonding at the main panel
 - For step-down transformers: Consult the manufacturer for grounding instructions

Disconnect switches for all ungrounded AC input conductors must be installed by others, complying with the National Electrical Code (*ANSI/NFPA 70*).

Verify proper grounding:

7c. Contents

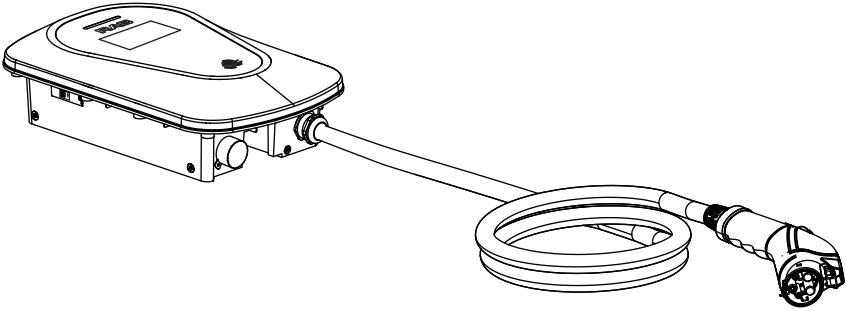

AC charger
with charging cable

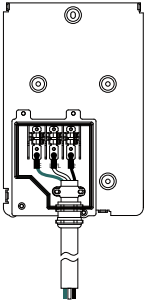

Mounting Bracket
× 1

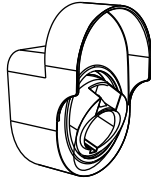

Nozzle Holder × 1

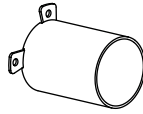

Protective Cover × 1



Connector × 1



Expansion
Screw × 8



M5 Self-Tapping
Screw × 8

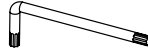

Torx/ T25
L-Wrench × 1

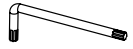

Torx/ T20
L-Wrench × 1

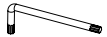

Torx/ T10
L-Wrench × 1



KM5
Screw × 4



Tweezers × 1

7d. Tools and Materials Required

Tools required before installing the charger onto the Wall-Mount Bracket are:

- Wire stripper.
- Phillips screwdriver for M4—M6 1 ³/₈ inch or 6 mm drill diameter.
- Voltmeter or digital multimeter (*for measuring AC voltage at the installation site*).
- The installed cable should meet the best waterproof performance requirements. it is recommended to use a 3-core 6 AWG to pull the cable from the distribution box. The maximum outer diameter of the cable should be ⁵/₈ - ⁷/₈ inch.
- Bubble level
- Pencil or marker
- Drill
- Slotted head screwdriver for M5.

7e. Wall-Mount Installation Requirements

Before installing the wall-mount bracket, you should Confirm the load capacity of the wall exceeds 88.18 lbs. When installing on a concrete wall, you can use the included expansion screws to install the bracket and use a hammer drill to drill holes on the concrete wall (*Dia 1/4 inch*) following the hole spacing.

When installing on a wooden wall, use the included M5 self-tapping screws to install the wall-mount bracket .

- To select the best location and position to install the wall-mount unit, you should first determine the parking position of the vehicle to ensure the charging connector can be easily inserted into the vehicle charging inlet.
- The wall-mount unit should be located:
 - In a well-ventilated area. Avoid installing in closed spaces or near to exothermic chargers.
 - 1.2 meters or 4 feet above the floor.
 - 10 inches from any obstacles to allow cables to loop around the wires and to allow related maintenance.
 - If in an enclosed garage, Install the EV Charger on the side of vehicle charging inlet.

7f. Charger Installation

Input cable wiring

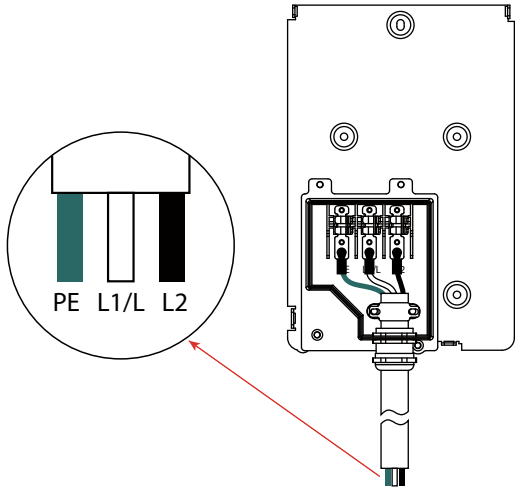

If necessary, install the power cable according to the markings inside the junction box.

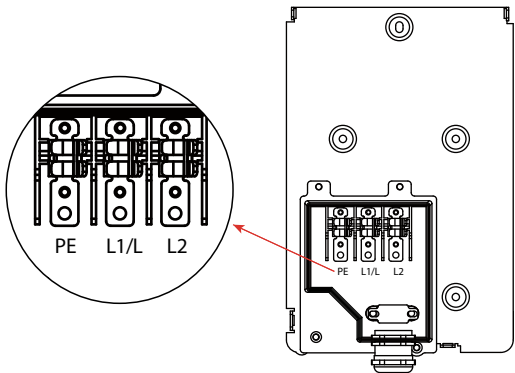

Use Mounting bracket to mark on the wall

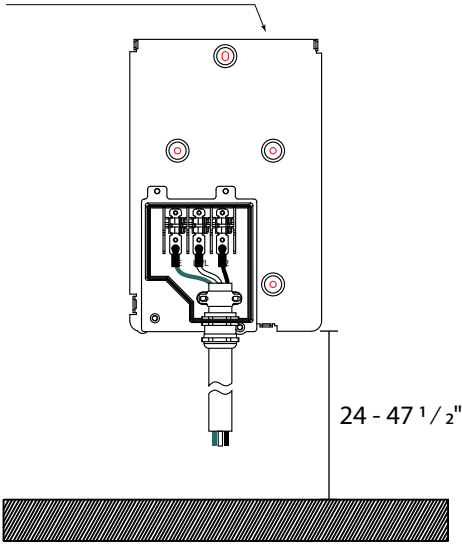

Height from ground 24 - 47 1/2"

Drill 4 holes on the wall (Dia 1/4")
Secure the expansion screws

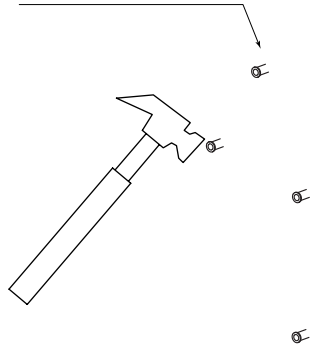

Secure the mounting bracket to the wall with M5 self-tapping screws

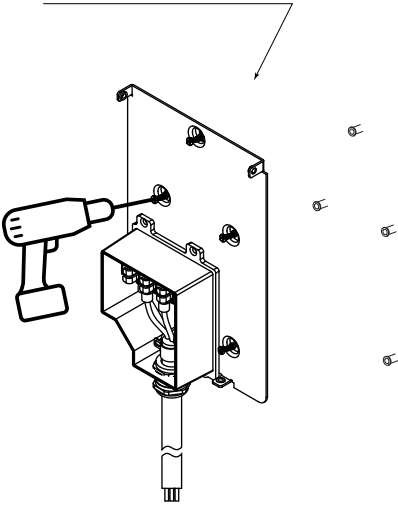

Press charger firmly into mounting bracket

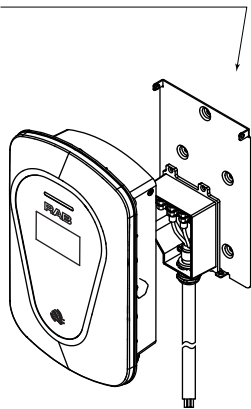

Align the four screw holes of the equipment with the four holes on the mounting bracket. Push the charger until the screw holes are perfectly aligned, then tighten them using the KM5 screws with torx/ T25 L-wrench, the tightening torque is 30 kg-cm.

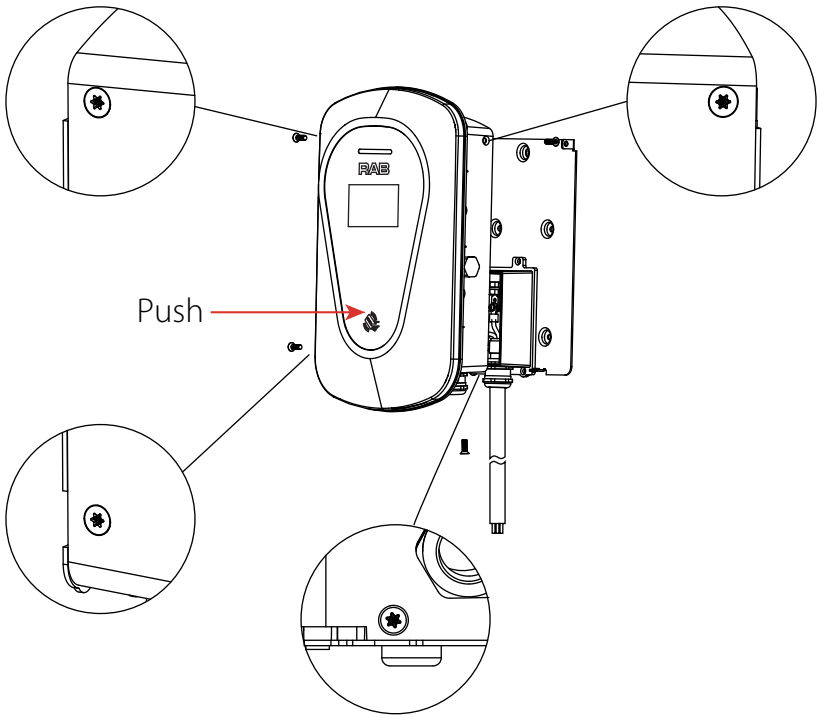

Note: This device shall be mounted at a sufficient height from the ground, such that the height of the storage unit for the coupling device is between 18" and 48" above ground for indoor use, and between 24" and 48" above ground for outdoor use.

Installation of 4G Card (for 4G mode)

Remove the screws with torx/ T10 L-wrench , open the cover, and insert the Micro-SIM card in the direction shown below (with the metal contacts facing down).

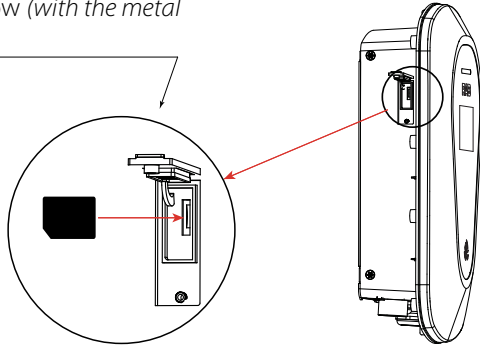

Close the cover and lock the screws.

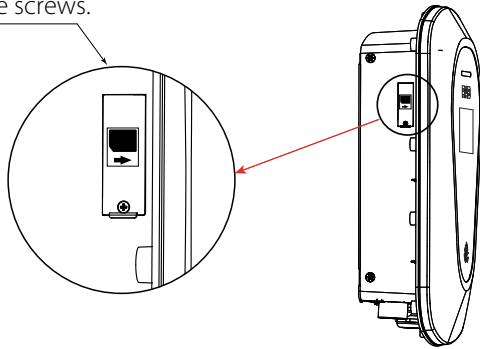

Method for Removing the 4G Card

Gently press the 4G card with tweezers to make it pop up, then lift it out.

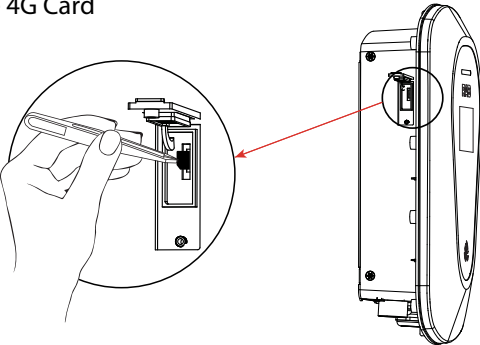

Note: The 4G module's network hotspot signal range is 25 meters, supporting simultaneous connection of up to 5 charging stations.

Installation of Ethernet cable (for Ethernet mode)

Remove the screw with torx/ T10 L-wrench, detach the protective cover and netting port cover.

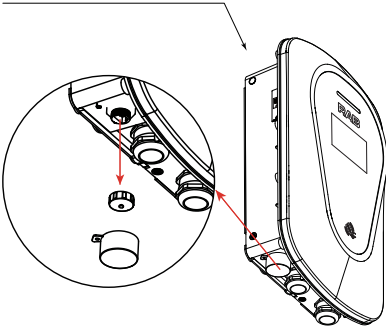

Thread the Ethernet cable through the connector and protective cover (in the charger accessories).

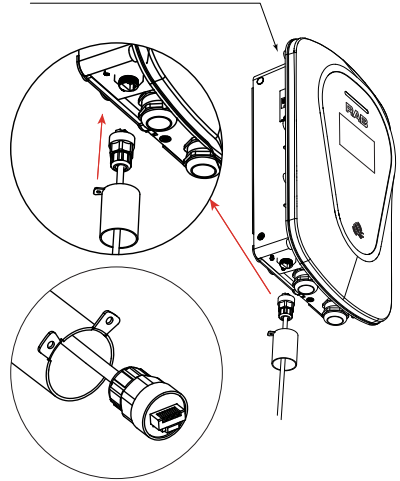

Tighten the connector.

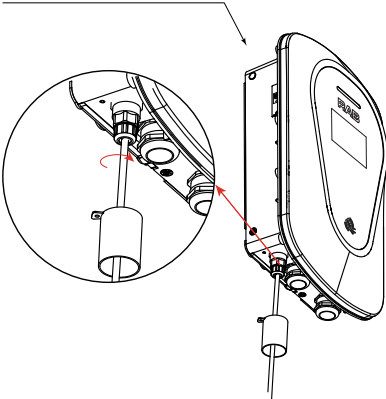

Secure the protective cover to the charger .

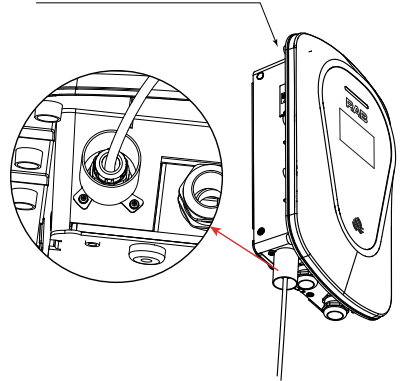

Charging Connector Holder

Remove the bottom screws with torx/ T20 L-wrench

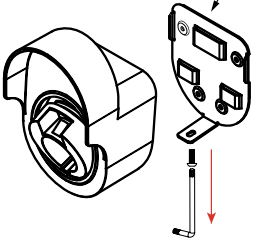

Use nozzle holder bracket to mark on the wall, drill 4 holes (Dia 1/4"), secure the expansion screws

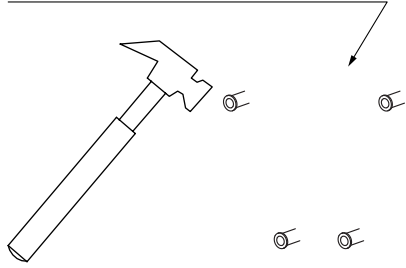

Secure the nozzle holder bracket to the wall with 4 M5 self-tapping screws

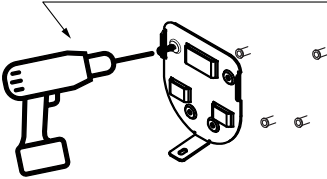

Align the nozzle holder to the bracket

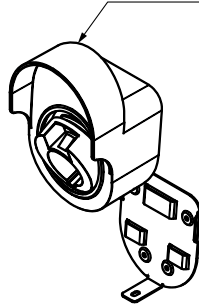

The nozzle holder slides down to fit in the bracket

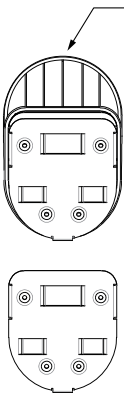

Lock the anti-theft screw with torx/ T20 L-wrench

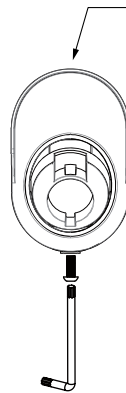

Installation of Charging Connector Wiring

Wrap the charging cable around the nozzle to prevent it from hanging down, then insert the connector into the nozzle hole to complete the installation.

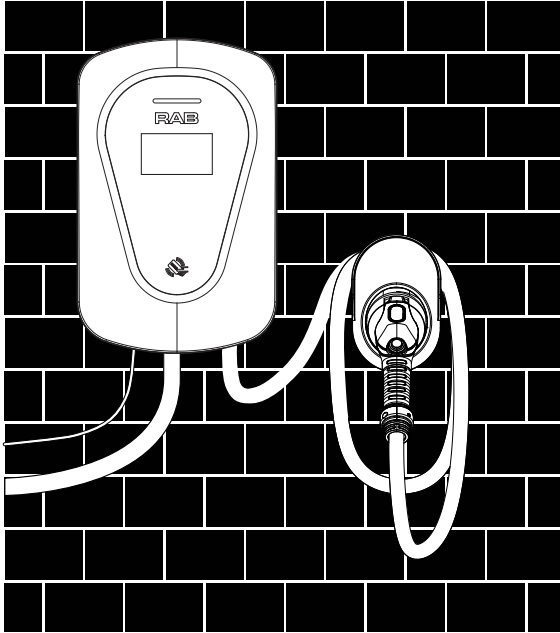

7g. Input Device Requirements

EVC48 (48A rated EV Charger):

Cable for Hardwire: 3X6AWG

Breaker: Minimum requirements 60A/2P

8. Charging Operation Flowchart

8a. Online APP Control

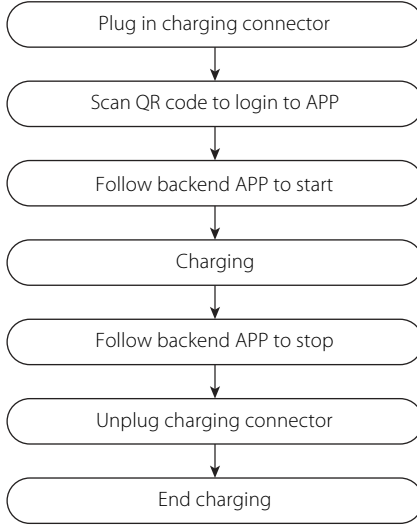

8b. Local RFID Card (pre-registered)

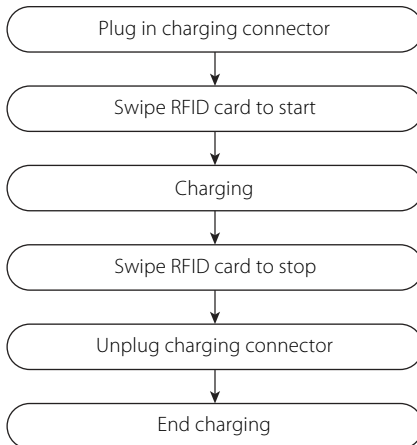

8c. Local Plug & Play

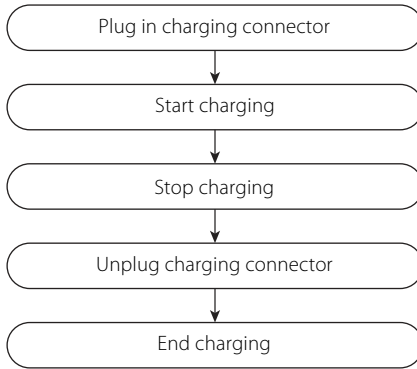

9. Maintenance

Please keep the charger clean and install it in a clean, low-humidity area. Do not install it in coastal environments or areas with high levels of oil, humidity, or dust.

- Prevent water from entering the charger. If water enters the charger, immediately power it off to avoid danger. Contact a professional technician before next use.
- Use the charger correctly. Do not hit or apply excessive pressure to the case. If the case is damaged, contact a professional technician.
- Avoid placing the charger near hot objects or in high-temperature locations, and keep it away from hazardous materials such as flammable gases and corrosive substances.
- Do not place foreign or heavy objects on the charger to avoid danger.

10. Warranty

Electric Vehicle Charger products are free from defects in materials and workmanship for a period of three (3) years from the date of original sale to RAB's distributor. The product shall be considered defective only if it cannot be returned to service with assistance from an RAB technical product support representative. If you have a technical issue or question regarding the warranty, contact our technical support team at the RAB HelpLine. Exceptions apply as stated on the product specification sheets incorporated herein by reference. Defects in materials or workmanship do not include improper installation or operation, alterations, power surges, or overheating due to external conditions. Defects caused by acts of vandalism and incidents beyond the control of the manufacturer, resulting in the inoperability of the electric vehicle charger are not covered by the material or workmanship warranty.

CAUTION: Changes or modifications to this equipment not expressly approved by RAB Lighting may void the user's authority to operate this equipment.

WE'RE HERE TO HELP:

1 (844) LIGHTCLOUD

1 (844) 544-4825

support@lightcloud.com

Technical Support:

844-544-4825

RAB[®]

© 2026 RAB Lighting Inc.

P-102379