

INSTRUCTIONS

SWISH® FA INSTALLATION

RAB®

RAB Lighting is committed to creating high-quality, affordable, well-designed and energy-efficient LED lighting and controls that make it easy for electricians to install and end users to save energy. We'd love to hear your comments. Please call the Marketing Department at 888-RAB-1000 or email: marketing@rablighting.com



SWISHFA -2X2



SWISHFA -2X4

IMPORTANT

READ CAREFULLY BEFORE INSTALLING FIXTURE. RETAIN THESE INSTRUCTIONS FOR FUTURE REFERENCE.

RAB fixtures must be wired in accordance with the National Electrical Code and all applicable local codes. Proper grounding is required for safety. THIS PRODUCT MUST BE INSTALLED IN ACCORDANCE WITH THE APPLICABLE INSTALLATION CODE BY A PERSON FAMILIAR WITH THE CONSTRUCTION AND OPERATION OF THE PRODUCT AND THE HAZARDS INVOLVED.

WARNING: Make certain power is OFF before installing or maintaining fixture. No user serviceable parts inside.

CAUTION: For proper weatherproof function all gaskets must be seated properly and all screws inserted and tightened firmly. Apply weatherproof silicone sealant around the edge of the ceiling mounting box and/or junction box. This is especially important with an uneven ceiling surface. Silicone all plugs and unused conduit entries.

RECESSED CEILING MOUNTING

The fixture is suitable only for INDOOR RECESSED CEILING application. Above ceiling access required.

To mount in an insulated or non-insulated ceiling - 9/16" or 15/16" exposed Flat Tee Grid Ceiling follow the steps below.

1. Rotate and slide the **Housing** as required to fit through the **Tee-Grid Bar** and place it as indicated by the directional arrow as shown in Fig. 1.
2. Firmly bend the pre-installed **Grid Clips (4)** against the **Tee-Grid Bar** to secure the **Housing** as shown in Fig. 2
3. Support wires are required by Installation Codes. Support the **Housing** to the building structure by **Support Wires (supplied by others)** through the **Support Wire Hole** as shown in Fig. 3.
4. Make sure that the orientation of the **Access Plate** faces an accessible tile to make electrical splices.
5. Loosen screw on **Access Plate** and remove the **Access Plate** (Fig. 1). Knock out appropriate **Conduit Knockouts** on the **Access Plate** to route input conduit. Use appropriate conduit connectors as required by code.
6. Connect wires as shown in wiring diagram (Fig 4). Push all wires back into the **Splice Box**. Be careful not to pinch wires. **WARNING: To prevent wiring damage or abrasion, do not expose wiring to edges of sheet metal or other sharp objects.**
7. Replace **Access Plate** and tighten **Access Plate Screw**.
8. After installation, remove protective film from the outer surface of the lens.

Fig: 1

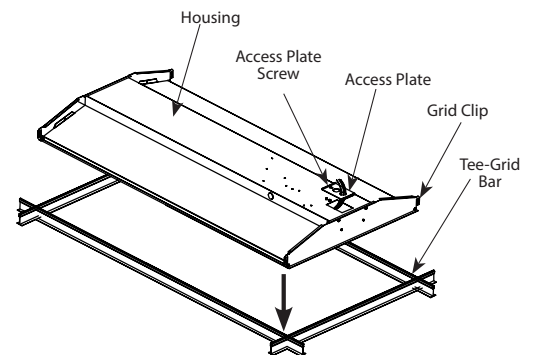

Fig: 2

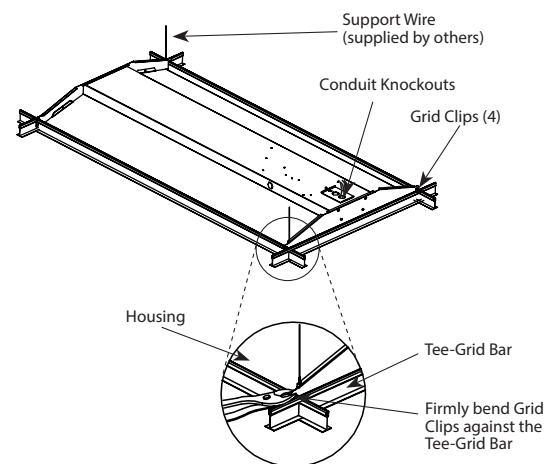
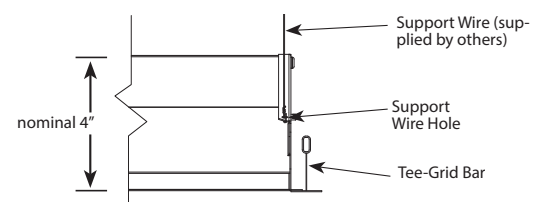

Fig: 3



INSTRUCTIONS

SWISH® FA INSTALLATION



RAB Lighting is committed to creating high-quality, affordable, well-designed and energy-efficient LED lighting and controls that make it easy for electricians to install and end users to save energy. We'd love to hear your comments. Please call the Marketing Department at 888-RAB-1000 or email: marketing@rablighting.com

0-10V DIMMABLE WIRING

Universal voltage driver permits operation at 120V thru 277V, 50 or 60 Hz. 0-10V control wires must be rated for 300V minimum. For 0-10V Dimming, follow the wiring directions shown below.

1. Connect the black fixture lead to the LINE supply lead.
2. Connect the white fixture lead to the COMMON supply lead
3. Connect the GROUND wire from fixture to supply ground. Do NOT connect the GROUND of the dimming fixture to the output
4. Connect the violet fixture lead to the (V+) DIM lead.
5. Connect the gray fixture lead to the (V-) DIM lead.

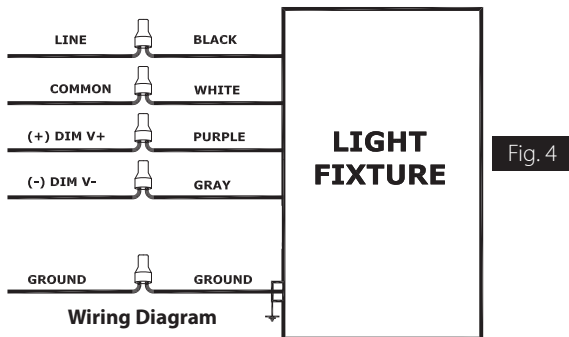

CLEANING & MAINTENANCE

CAUTION: Be sure fixture temperature is cool enough to touch. Do not clean or maintain while fixture is energized.

1. Clean polycarbonate lens & fixture with non-abrasive cleaning solution.
2. Do not open fixture to clean the LEDs. Do not touch the LEDs.

TROUBLESHOOTING

1. Check that the line voltage at the fixture is correct. Refer to wiring directions.
2. Is the fixture grounded properly?

FIELD ADJUSTMENT

Follow instructions below to change the fixture wattage or color temperature from the factory settings.

Factory Settings: 2X2 - 29W, 4000K, 2X4 - 39W, 4000K

1. Locate the selector switches on the side of the driver as shown in Fig 5.
2. Select a color temperature and wattage by sliding the respective switch to the desired value (Fig 6).
3. After the switches are positioned to the desired settings, insert the Silicone Plugs (provided) to lock the switches in place.

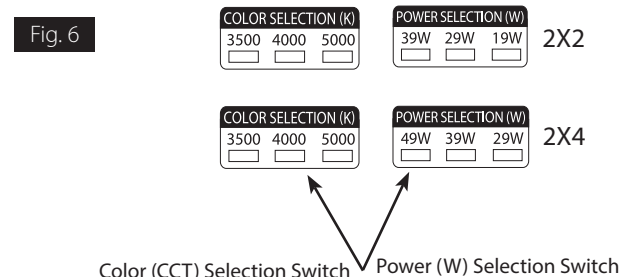
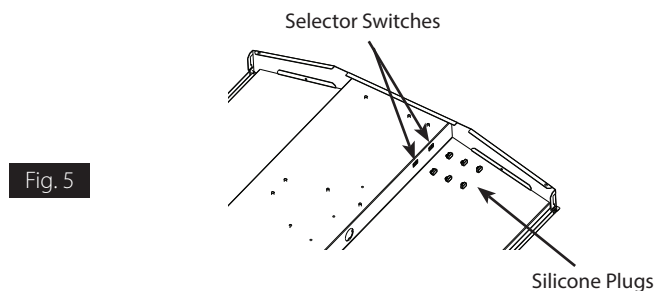

INSTRUCTIONS

SWISH® FA INSTALLATION

RAB®

RAB Lighting is committed to creating high-quality, affordable, well-designed and energy-efficient LED lighting and controls that make it easy for electricians to install and end users to save energy. We'd love to hear your comments. Please call the Marketing Department at 888-RAB-1000 or email: marketing@rablighting.com

BATTERY BACKUP MODELS

WIRING

CAUTION: FOR BATTERY BACKUP FIXTURE. Voltage can be present in **BATTERY**. To prevent high voltage from being present on output leads, Inverter connector must be open. Do not join **BATTERY** connector until installation is complete and AC power is supplied to the emergency driver. (Fig. 7)

NOTE: Make sure that the necessary branch circuit wiring is available. An **UNSWITCHED** AC source of power is required. The emergency driver must be fed from the same branch circuit as the LED driver.

CAUTION: Do not use any supply voltage other than 120-277V 50/60 HZ.

1. Connect **UNSWITCHED HOT** fixture lead to **HOT AC** supply line.
2. If using an **UNSWITCHED** circuit, connect **UNSWITCHED** and **SWITCHED** lines together.
3. If using a **SWITCHED** circuit, connect **SWITCHED HOT** AC fixture lead to the external
4. Connect the gray fixture lead to the (V-) DIM lead.
5. For 0-10V Dimming, connect **DIM (+)** and **DIM (-)** to the supply ground. Do not connect **GROUND** to the output leads.
6. All unused lead must be capped and insulated.
7. After installation is complete, supply AC power to the fixture and connect the **BATTERY**.
8. When power is on, the fixture should be on and the Charging Indicator Light should illuminate to indicate the battery is charging.
9. Once the **BATTERY** has charged for at least one hour, a short duration test may be performed by pressing the test button.
10. After the battery has charged for 24 hours, a long duration test can be performed by shutting power to the fixture.

OPERATION

1. When AC power is applied, the charging indicator light is illuminated, including that the **BATTERY** is being charged.
2. When power fails, the standby power automatically switches to emergency power (internal battery), operating at reduced illumination. The emergency driver supplies 8W of power for SWISHFA 2x2 and 16W of power for SWISHFA 2x4 in standby power for a minimum of 90 minutes.
3. When AC power is restored, the emergency driver automatically returns to charging mode.

MAINTENANCE

Although no routine maintenance is required to keep the emergency driver functional, it should be checked periodically to ensure that it is working. The following schedule is recommended:

1. Visually inspect the charging indicator light monthly. It should be illuminated
2. Test the emergency operation of the fixture at 30-day intervals for a minimum of 30 seconds.
3. Conduct a 90-minute discharge test once a year. Fixture would operate at reduced illumination for a minimum of 90 minutes.

TROUBLESHOOTING

1. Is the fixture grounded properly?
2. If the charging indicator light does not illuminate after pressing the test button, check if battery is connected properly.

FIG. 7

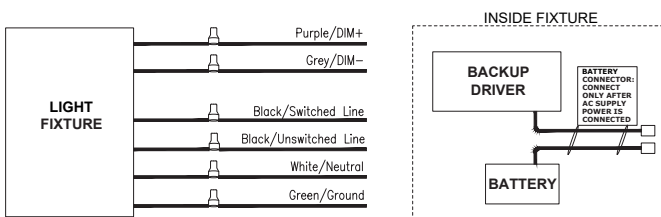

Note: These instructions do not cover all details or variations in equipment nor do they provide for every possible situation during installation, operation or maintenance.

RAB®
© 2020 RAB LIGHTING Inc.
Northvale, New Jersey 07647 USA

Easy Answers

rablighting.com
Visit our website for product info

Tech Help Line
Call our experts: 888 722-1000

e-mail
Answered promptly - sales@rablighting.com

Free Lighting Layouts
Answered online or by request

RAB Lighting is committed to creating high-quality, affordable, well-designed and energy-efficient LED lighting and controls that make it easy for electricians to install and end users to save energy. We'd love to hear your comments. Please call the Marketing Department at 888-RAB-1000 or email: marketing@rablighting.com

BATTERY BACKUP MODELS

WIRING

CAUTION: FOR BATTERY BACKUP FIXTURE. Voltage can be present in **BATTERY**. To prevent high voltage from being present on output leads, Inverter connector must be open. Do not join **BATTERY** connector until installation is complete and AC power is supplied to the emergency driver. (Fig. 7)

NOTE: Make sure that the necessary branch circuit wiring is available. An **UNSWITCHED** AC source of power is required. The emergency driver must be fed from the same branch circuit as the LED driver.

CAUTION: Do not use any supply voltage other than 120-277V 50/60 HZ.

1. Connect **UNSWITCHED HOT** fixture lead to **HOT AC** supply line.
2. If using an **UNSWITCHED** circuit, connect **UNSWITCHED** and **SWITCHED** lines together.
3. If using a **SWITCHED** circuit, connect **SWITCHED HOT** AC fixture lead to the external
4. Connect the gray fixture lead to the (V-) DIM lead.
5. For 0-10V Dimming, connect **DIM (+)** and **DIM (-)** to the supply ground. Do not connect **GROUND** to the output leads.
6. All unused lead must be capped and insulated.
7. After installation is complete, supply AC power to the fixture and connect the **BATTERY**.
8. When power is on, the fixture should be on and the Charging Indicator Light should illuminate to indicate the battery is charging.
9. Once the **BATTERY** has charged for at least one hour, a short duration test may be performed by pressing the test button.
10. After the battery has charged for 24 hours, a long duration test can be performed by shutting power to the fixture.

OPERATION

1. When AC power is applied, the charging indicator light is illuminated, including that the **BATTERY** is being charged.
2. When power fails, the standby power automatically switches to emergency power (internal battery), operating at reduced illumination. The emergency driver supplies 8W of power for SWISHFA 2x2 and 16W of power for SWISHFA 2x4 in standby power for a minimum of 90 minutes.
3. When AC power is restored, the emergency driver automatically returns to charging mode.

MAINTENANCE

Although no routine maintenance is required to keep the emergency driver functional, it should be checked periodically to ensure that it is working. The following schedule is recommended:

1. Visually inspect the charging indicator light monthly. It should be illuminated
2. Test the emergency operation of the fixture at 30-day intervals for a minimum of 30 seconds.
3. Conduct a 90-minute discharge test once a year. Fixture would operate at reduced illumination for a minimum of 90 minutes.

TROUBLESHOOTING

1. Is the fixture grounded properly?
2. If the charging indicator light does not illuminate after pressing the test button, check if battery is connected properly.

FIG. 7

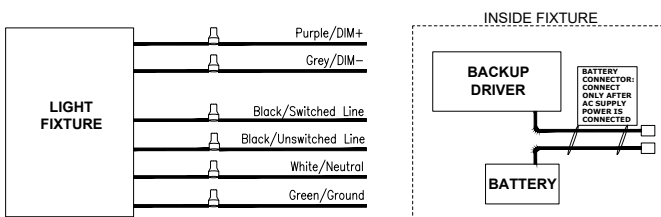

Note: These instructions do not cover all details or variations in equipment nor do they provide for every possible situation during installation, operation or maintenance.

19724 MICROWAVE SENSOR FOR D10

Thank you for buying RAB lighting fixtures. Our goal is to design the best quality products to get the job done right. We'd like to hear your comments. Call the Marketing Department at 888-RAB-1000 or email: marketing@rabweb.com

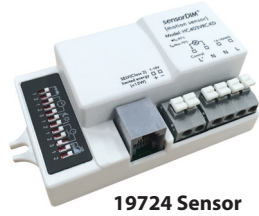

IMPORTANT

READ CAREFULLY BEFORE INSTALLING FIXTURE. RETAIN THESE INSTRUCTIONS FOR FUTURE REFERENCE.

19724 is used with a 120-277VAC dimmable driver and comes with a sensor antenna. Sensor is shipped with Factory Settings outlined below under **DIP Switch Settings**. If settings other than factory pre-sets are desired, the consumer may change DIP Switch Settings. For more detailed control of the sensor, the consumer can purchase MVSREM wireless commissioning tool (remote) to re-program sensor settings.

DIP SWITCHES

Factory Settings shown below

SPECIFICATIONS

Sensor is not suitable for wet locations.

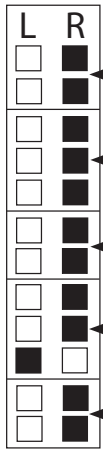
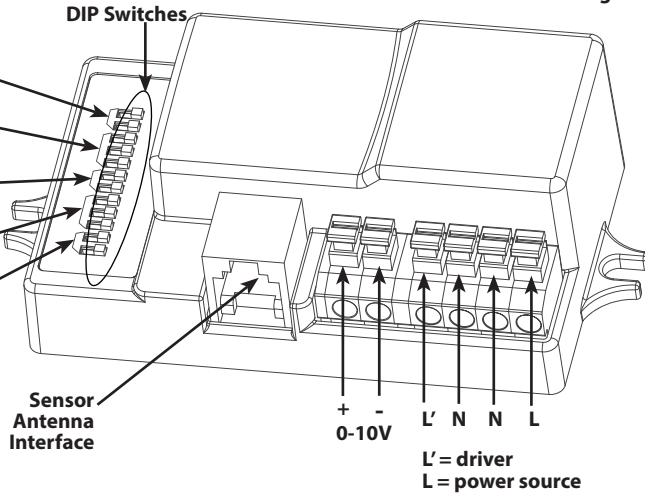

Fig. 1

- Adjustable Detection Area
- Time Delay
- Daylight Sensor
- Cut Off Period
- Dim Level



DIP Switch Settings

Switch positions referred to as R for right position and L for left position when looking at sensor in orientation shown in Fig. 2, in which all switches are R. See Fig. 1 and 2 for each setting's corresponding switches. Setting options for each category are noted in (parenthesis) below.

Factory Settings: designated in **bold** for each category

Detection Area:

- **100% (RR)** • 50% (LR)
- 75% (RL) • 10% (LL)

Time Delay: how long lamp remains on at 100% after last recognized motion

- **5s (RRR)** • 10min (LRR)
- 30s (RRL) • 20min (LRL)
- 1min (RLR) • 30min (LLL)
- 5min (RLL)

Daylight Sensor:

- **Disabled (RR)** • 1 fc (Twilight) (LR)
- 5 fc (Daylight) (RL) • .2 fc (Darkness) (LL)

Cut Off Period: how long reduced light output lasts after time delay period before fixture switching off

- 0s (RRR) • 10min (LRR)
- **10s (RRL)** • 30min (LRL)
- 1min (RLR) • 1hr (LLR)
- 5min (RLL) • Always (LLL)

Dim Level: light output level after time delay

- **10% (RR)** • 30% (LR)
- 20% (RL) • 50% (LL)

19724 MICROWAVE SENSOR FOR D10

Thank you for buying RAB lighting fixtures. Our goal is to design the best quality products to get the job done right. We'd like to hear your comments. Call the Marketing Department at 888-RAB-1000 or email: marketing@rabweb.com

OPERATION

Multi-level Dimming:

- 100% light
- Dimmed to: 10, 20, 30, 50*%
**50% not on remote*
- Off

Cut Off Time Adjustment:

- Once room is vacated, light dims to selected % after chosen hold time elapses

Daylight Sensing:

- Surrounding natural light keeps fixture light off until room is occupied and natural light levels drop to selected level

8 Hour* Manual Mode:

- Turn fixture off-on 3 times within 3 seconds
- Green LED on antenna will flash and fixture will flash 3 times if done correctly
- Fixture will remain 100% for 8 hours, then sensor will come on automatically
- To cancel, turn the fixture off-on within 1 second

**Times out after one 8-hour cycle*

Ambient Daylight Threshold*:

- Turn fixture off-on 2 times within 2 seconds
- Green LED on antenna will flash slowly for 5 seconds and fixture will blink twice if done correctly
- Surrounding fc will be measured and recorded for 1 second
- Green LED on antenna and fixture will light for 10 seconds to indicate successful fc recording
- Most recent fc measurement overwrites any prior

**DIP settings (pg 1) and ambient lux overwrite each other depending on latest action*

Scene Mode:

- 100% detection range and 10% cut off dimming
- Scene 1 (SC1):** 1 min hold-time, 10 min cut off period, .2 fc daylight sensor
- Scene 2 (SC2):** 5 min hold-time, 10 min cut off period, .2 fc daylight sensor
- Scene 3 (SC3):** 10 min hold-time, 30 min cut off period, 1 fc daylight sensor
- Scene 4 (SC4):** 10 min hold-time, always on bi-level cut off period, 5 fc daylight sensor

SENSOR COVERAGE DIAGRAM

Below diagrams represent best average coverage from lab testing. Actual coverage may vary as metal on the fixtures can interfere with microwaves from the sensor

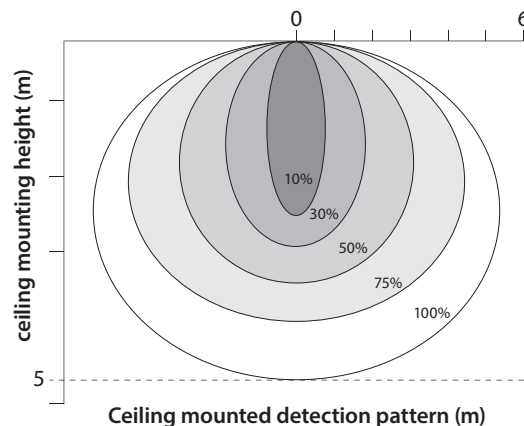

Fig. 3

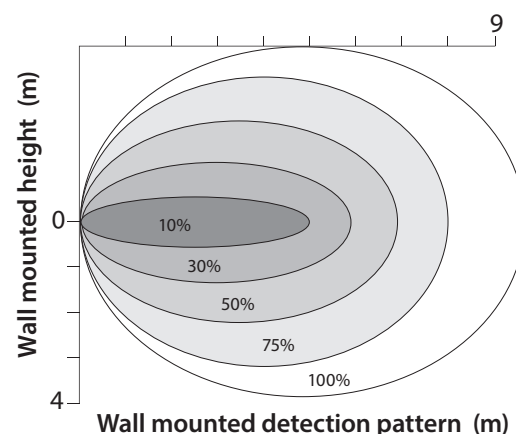

Fig. 4

SENSOR TECHNICAL DATA

Capacitance Load: 400W at 120V, 800W at 230V, 1000W at 277V

Operating Temperature: -20°C to +60°C (-4°F to +140°F)

Relay: Zero-cross relay

Maximum Mounting Height: 5m

Customizable Detection Area: 10, 50, 75 or 100%

Time Delay: 5s, 30s, 1min, 5min, 10min, 20min, 30min

Cut Off Period: 0s, 10s, 1min, 5min, 10min, 30min, 1hr, Bi-Level

Cut Off Dimming Level: 10, 20, 30, 50%

Cut Off Power: Less Than 1W

Daylight Threshold: About .2-5 fc or Disabled

Sensor Principle: High Frequency

Microwave Frequency: 5.8GHz +/- 75MHz

Microwave Power: <0.2mW

Detection Range Max: 16m across, 10m high

Detection Angle: About 30 to 150 degrees

19724 MICROWAVE SENSOR FOR D10

Thank you for buying RAB lighting fixtures. Our goal is to design the best quality products to get the job done right. We'd like to hear your comments. Call the Marketing Department at 888-RAB-1000 or email: marketing@rabweb.com

REMOTE

Sensor will beep one time to indicate remote received successfully

Remote settings will override DIP Switch settings

ON/OFF: disables sensor; light is permanently* on or off

*un-do permanent on/off by selecting either Auto-Mode, RESET, or any Scene mode button

Auto Mode: sensor activates and all previously selected settings remain programmed

RESET: overrides selected settings; reverts to DIP settings

Dim buttons: + dims up and - dims down, adjusting lamp brightness

Black Button: no function

Test 2s: automatic* test mode with 2 second time delay; disables cut off period and daylight sensor

*un-do automatic test mode by selecting either RESET, any Scene mode button, or hold time

Power 100% & Power 80%: adjusts power output; to save energy select Power 80%. Must return to full output after initial 10,000 hours of LEDs by pressing Power 100%.

Group B:

Yellow Sun Button: Ambient Daylight Threshold; records surrounding lux level and overwrites previously recorded value

.2, 1 and 5 fc: sets daylight sensor at respective ambient light values

Disable: disables daylight sensor; any motion registered by sensor activates fixture light

SC1, SC2, SC3, SC4: assigns one of 4 pre-set scenes; see "Operation" on pg 2 for scene descriptions

Fig. 5

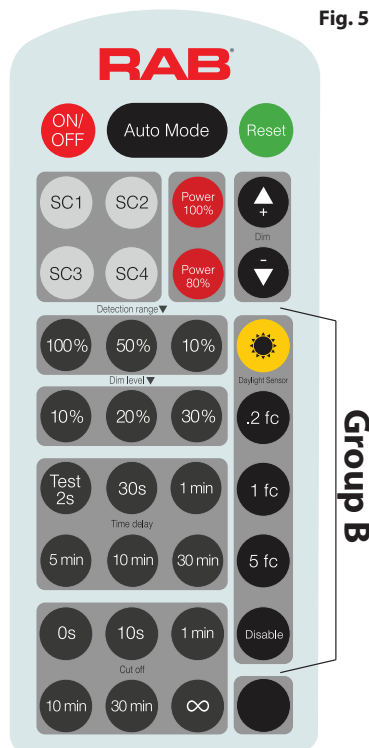

REMOTE CONTINUED

Detection Range Button Group: assigns detection range of 10, 50 or 100%; use coverage diagrams on pg 2 for guidance. To limit area in which motion will set off sensor, use a smaller percent. The sensor will not detect motion outside of 100% and the fixture will not light.

Time Delay Button Group: assigns hold time of 30 seconds, 1 minute, 5 minutes, 10 minutes, or 30 minutes

Cut Off Button Group: assigns cut off period of 0 seconds, 10 seconds, 1 minute, 10 minutes, 30 minutes, or 1 hour. 0 seconds gives fixture on/off control rather than dimming. + ∞ keeps the light on always (if daylight sensor is disabled) with Bi-Level dimming control.

Dim Level: assigns level of 10, 20, or 30% for dimmed light output after time delay passes

TROUBLESHOOTING

If the sensor does not detect motion as expected:

- Check fixture mounting to compare fixture location and sensor coverage with the coverage diagrams on pg 2
- Adjust fixture location as necessary

Fixture will not light/sensor does not detect motion:

- Make sure ON/OFF button was not selected as this results in disabling the sensor
- Check all settings to be sure there is no conflicting selection with the ambient light level

Fixture and sensor are too active:

- Check detection area setting and reduce coverage as needed
- Increase time delay and/or adjust cut off period.

Basic Function Overview:

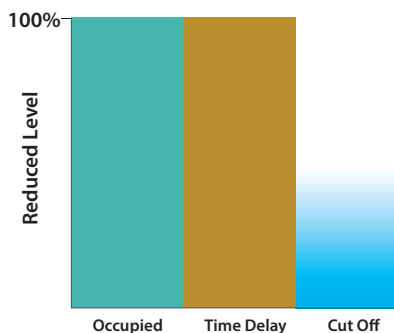

Fig. 6

Note: These instructions do not cover all details or variations in equipment nor do they provide for every possible situation during installation operation or maintenance.