

INSTRUCTIONS

VAN™ FIELD-ADJUSTABLE INSTALLATION

RAB®

RAB Lighting is committed to creating high-quality, affordable, well-designed and energy-efficient LED lighting and controls that make it easy for electricians to install and end users to save energy. We'd love to hear your comments. Please call the Marketing Department at 888-RAB-1000 or email: marketing@rablighting.com

**** DON'T TOSS IT—RECYCLE IT! MAKE THE SUSTAINABLE CHOICE BY RECYCLING THIS FIXTURE AT END OF LIFE WITH A LICENSED RECYCLING PROVIDER. ****

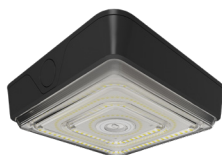

VAN40

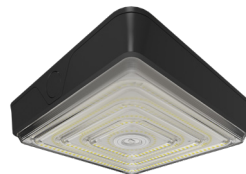

VAN75

IMPORTANT

READ CAREFULLY BEFORE INSTALLING FIXTURE. RETAIN THESE INSTRUCTIONS FOR FUTURE REFERENCE.

RAB fixtures must be wired in accordance with the National Electrical Code and all applicable local codes. Proper grounding is required for safety. THIS PRODUCT MUST BE INSTALLED IN ACCORDANCE WITH THE APPLICABLE INSTALLATION CODE BY A PERSON FAMILIAR WITH THE CONSTRUCTION AND OPERATION OF THE PRODUCT AND THE HAZARDS INVOLVED.

WARNING: Make certain power is OFF before installing or maintaining fixture. No user serviceable parts inside.

CAUTION: For proper weatherproof function all gaskets must be seated properly and all screws inserted and tightened firmly. Apply weatherproof silicone sealant around the edge of the Ceiling Mounting Box and/or Junction Box. This is especially important with an uneven ceiling surface. Silicone all plugs and unused conduit entries.

- Suitable for outdoor applications in wet locations.
- Not suitable for Pendant Mounting.

SURFACE MOUNTING

The fixture is suitable for outdoor applications in wet locations.

1. Open the fixture by loosening (2) fixture **Door Screws** as shown in Fig. 1.
2. Rotate the **Fixture Door** to open position.
3. Use the **Drill Template** on the inside **Back Housing** surface to match most standard junction boxes or utilize **Lag Bolt** locations (3) as shown in Fig. 2 to mount fixture to surface .
4. Line up fixture in desired location and secure to mounting surface. Check that the **Junction Box Gasket** is fully seated.
5. Feed fixture wires through center hole of housing or through one of the (3) **Plugs** to make electrical splices. Make electrical connections as shown in wiring diagram (Fig. 4). Use approved wiring connectors and wire to NEC codes.
6. Close **Fixture Door** and secure with (2) **Screws**. Be careful not pinch wires.
7. Use silicone or Teflon® tape or thread sealer on all **Plugs** and on the threads of all conduit entry points. If outdoor surface is irregular, use caulk to seal any gaps around the ceiling.

Fig: 1

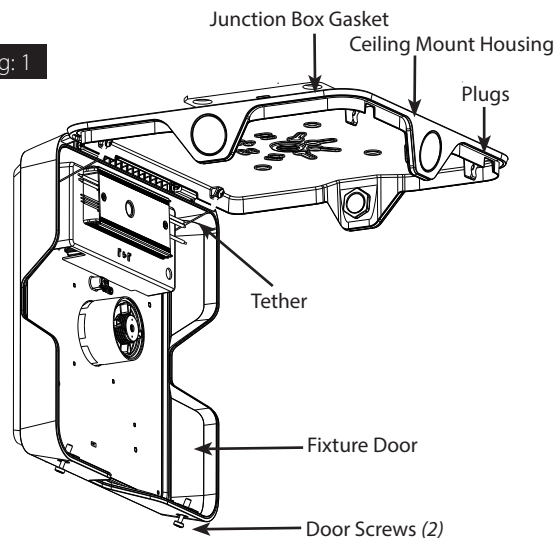
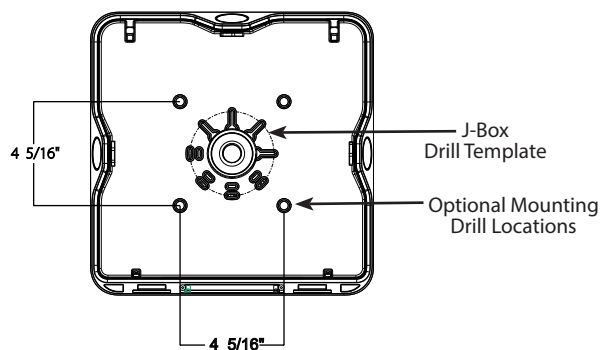

Fig: 2



INSTRUCTIONS

VAN™ FIELD-ADJUSTABLE INSTALLATION

RAB®

RAB Lighting is committed to creating high-quality, affordable, well-designed and energy-efficient LED lighting and controls that make it easy for electricians to install and end users to save energy. We'd love to hear your comments. Please call the Marketing Department at 888-RAB-1000 or email: marketing@rablighting.com

**** DON'T TOSS IT—RECYCLE IT! MAKE THE SUSTAINABLE CHOICE BY RECYCLING THIS FIXTURE AT END OF LIFE WITH A LICENSED RECYCLING PROVIDER. ****

FIELD ADJUSTMENT

Optic Selection:

This product is equipped with Garage/Canopy Optic selection.

Color Temperature (CCT) Selection:

This product is equipped with 5000K, 4000K or 3000K CCT Color Temperature selection. For maximum light output use the 4000K Color Temperature.

Power (W) Selection:

VAN40 is equipped with 40/30/20W power output selection. VAN75 is equipped with 75/60/40W power output selection.

Follow instructions below to change **Color Temperature (CCT)**, **Power (W)** and/or **Optic selection (Garage or Canopy)** from factory settings.

Factory Settings:

VAN40 - 40W / 4000K / Canopy Optic

VAN75 - 75W / 4000K / Canopy Optic

1. Locate the **Selector Switches** on **Fixture Door Housing** as shown in Fig. 3.
2. Select **Color Temperature (CCT)**, **Power (W)** and/or **Optic** function by sliding the respective switch to the desired setting (Fig. 3).

Fig. 3

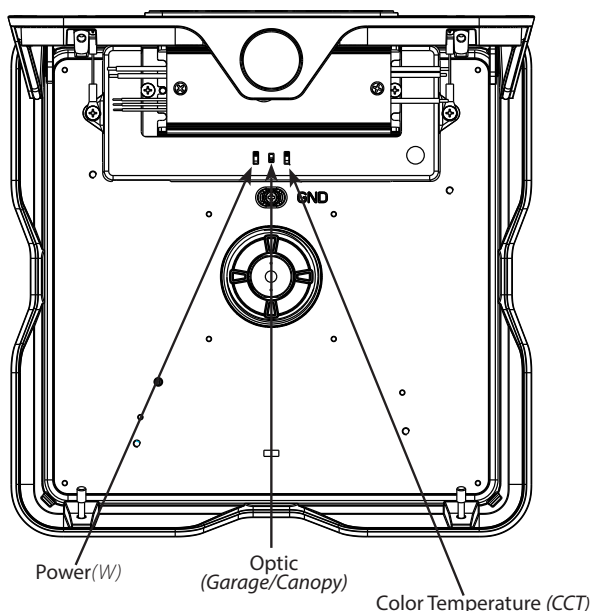

0-10V DIMMABLE WIRING

Universal voltage driver permits operation at 120V through 277V, 50 or 60 Hz. 480V suffix (/480) are 480V ONLY. For 0-10V dimming follow the wiring directions as shown in Fig. 4.

1. Connect the black fixture lead to the **LINE** supply lead.
2. Connect the white fixture lead to the **COMMON** supply lead.
3. Connect the **GROUND** wire from fixture to supply ground.
4. Connect the purple fixture lead to the (V+) DIM lead.
5. Connect the pink fixture lead to the (V-) DIM lead.
6. Cap the yellow fixture lead, if present. Do NOT connect.

Note: Do not connect DIM V+ (*purple*) /Dim V- (*pink*) to line Voltage or supply ground.

Fig. 4

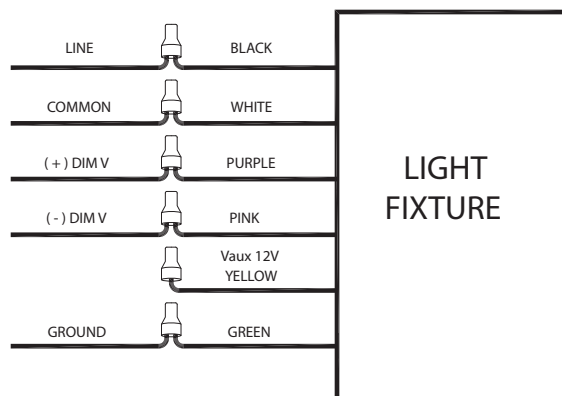

Note: 0-10V dimming circuit is not required with using Lightcloud Blue models.

INSTRUCTIONS

VAN™ FIELD-ADJUSTABLE INSTALLATION



RAB Lighting is committed to creating high-quality, affordable, well-designed and energy-efficient LED lighting and controls that make it easy for electricians to install and end users to save energy. We'd love to hear your comments. Please call the Marketing Department at 888-RAB-1000 or email: marketing@rablighting.com

**** DON'T TOSS IT—RECYCLE IT! MAKE THE SUSTAINABLE CHOICE BY RECYCLING THIS FIXTURE AT END OF LIFE WITH A LICENSED RECYCLING PROVIDER. ****

MVS SENSOR INSTALLATION

Sensor Model# MVS20, MVS20/LCB sold separately.

1. Open the housing as shown in Fig. 5.
2. Loosen the **Sensor Retaining Ring** from the threaded **Sensor Holder**.
3. Remove the **Sensor Socket** (*wires attached*) from it's holder and gently place through the **Sensor Retaining Ring**.
4. Thread the **MVS20** or **MVS20/LCB** sensor into the **Sensor Socket**.
5. Place the sensor into the **Sensor Holder**.
6. Tighten the **Sensor Retaining Ring**.

Fig. 5

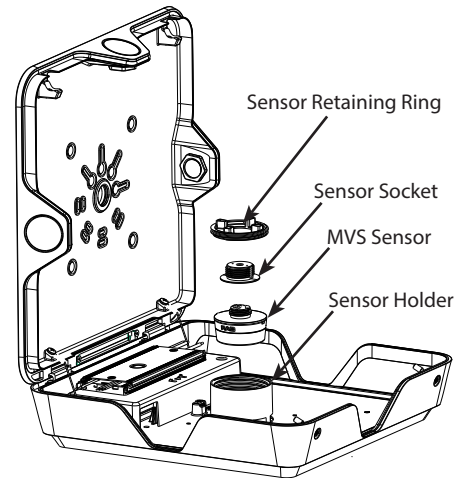

MVS DETECTION PATTERN

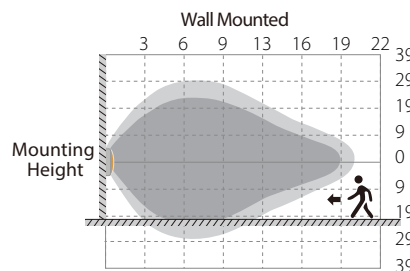
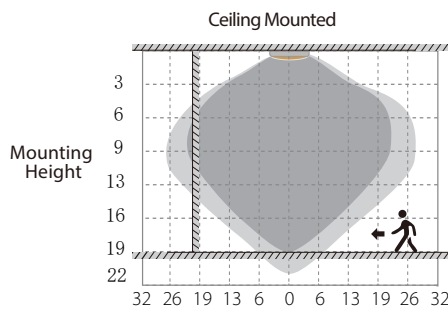

Highest mounting height is 20ft

This figure indicates the maximum distance at the highest mounting height with 100% sensitivity.

■ Well Detected Area ■ Possibly Detected Area

INSTRUCTIONS

VAN™ FIELD-ADJUSTABLE INSTALLATION



RAB Lighting is committed to creating high-quality, affordable, well-designed and energy-efficient LED lighting and controls that make it easy for electricians to install and end users to save energy. We'd love to hear your comments. Please call the Marketing Department at 888-RAB-1000 or email: marketing@rablighting.com

**** DON'T TOSS IT—RECYCLE IT! MAKE THE SUSTAINABLE CHOICE BY RECYCLING THIS FIXTURE AT END OF LIFE WITH A LICENSED RECYCLING PROVIDER. ****

PIR SENSOR INSTALLATION

Sensor Model# PIR20, PIR20/LCB sold separately.

1. Open the housing as shown in Fig. 6.
2. Loosen the **Sensor Retaining Ring** from the threaded **Sensor Holder**.
3. Use a slotted screwdriver to loosen and remove **Lens Cover** (located outside center of fixture lens) and **Lens Nut** on inside of **Sensor Holder**.
4. Remove the **Sensor Socket** (wires attached) from it's holder and gently place through the **Sensor Retaining Ring**.
5. Thread the **PIR20** or **PIR20/LCB** sensor into the **Sensor Socket**.
6. Place the sensor into the **Sensor Holder**.
7. Tighten the **Sensor Retaining Ring**.

Fig. 6

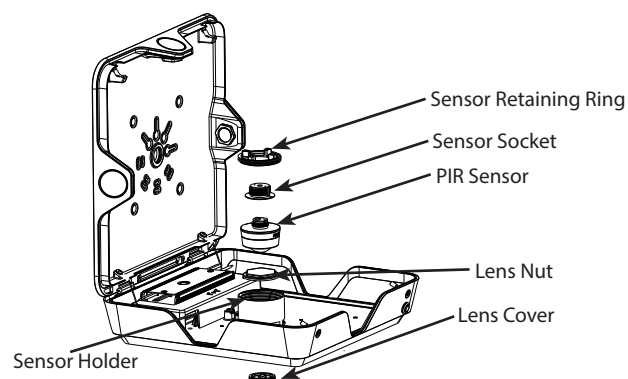

PIR DETECTION PATTERN

Mounting Height
<20ft Ceiling Mounted

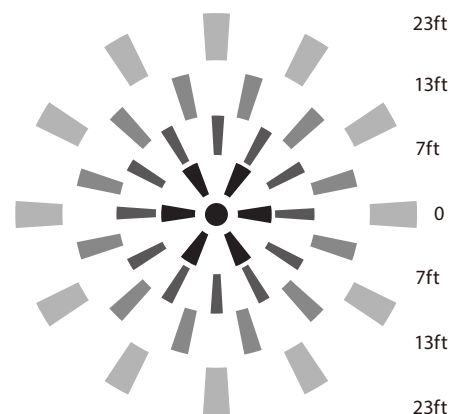
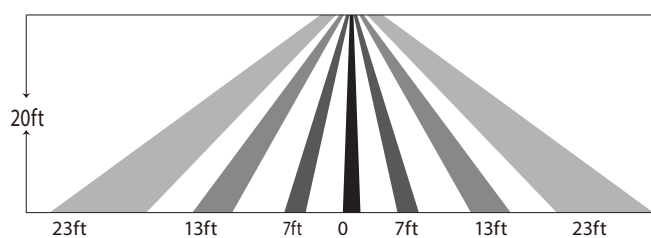

TROUBLESHOOTING

1. Check that the line voltage at the fixture is correct. Refer to wiring directions.
2. Be sure the fixture is grounded properly.

CLEANING & MAINTENANCE

CAUTION: Be sure fixture temperature is cool enough to touch. Do not clean or maintain while fixture is energized.

1. Clean lens with non-abrasive cleaning solution.
2. Do not open the fixture to clean the LEDs. Do not touch the LEDs.

Note: These instructions do not cover all details or variations in equipment nor do they provide for every possible situation during installation, operation or maintenance.

INSTRUCTIONS

VAN™ FIELD-ADJUSTABLE INSTALLATION



RAB Lighting is committed to creating high-quality, affordable, well-designed and energy-efficient LED lighting and controls that make it easy for electricians to install and end users to save energy. We'd love to hear your comments. Please call the Marketing Department at 888-RAB-1000 or email: marketing@rablighting.com

**** DON'T TOSS IT—RECYCLE IT! MAKE THE SUSTAINABLE CHOICE BY RECYCLING THIS FIXTURE AT END OF LIFE WITH A LICENSED RECYCLING PROVIDER. ****

LIGHTCLOUD BLUE MODELS

LIGHTCLOUD® BLUE

Lightcloud Blue is a Bluetooth mesh wireless lighting control system that allows you to control various compatible devices. With RAB's patented Rapid Provisioning technology, devices can be quickly and easily commissioned for residential and large commercial applications using the Lightcloud Blue mobile app. Each device in a system can communicate with any other device, eliminating the need for a Gateway or Hub and maximizing the control system's reach.

WIRING

Lightcloud Blue fixtures do NOT require any 0-10V or other low voltage wiring between fixtures. All communication for on/off, dimming, color tuning (*if applicable*) is done over Bluetooth mesh via the Lightcloud Blue mobile app. This device requires CONSTANT POWER for wireless communication.

INSTALLATION

Lightcloud Blue devices should be placed within the specified range (~60 ft) to communicate within the Bluetooth Mesh network. See product specification sheet for more details.

DOWNLOAD THE MOBILE APP

The Lightcloud Blue mobile app is available for iOS and Android mobile phones and tablets. The mobile app can be used to commission and control your devices.

Note: The mobile device is not part of the mesh network and must be within ≤ 30 feet from at least one device on the Site.



iOS Users



Android Users

RAPID PROVISIONING

This patented technology allows users to pair up to 100 fixtures simultaneously. Any Lightcloud Blue fixture or device that is powered on can be discovered during this process.

Pro Tip: Pair devices Area by Area or by circuit. Power on only the devices for a single Area and begin the pairing process. Once paired, move the devices to their assigned Area and move on to the next Area. Once a device is paired it cannot be discovered again.

Note: Be sure that only one user is logged into the Site during Rapid Provisioning and throughout the commissioning process to avoid unfavorable results.

WARNING!

DO NOT power on more than 100 devices during the Rapid Provisioning process to avoid unfavorable results.

CONFIGURATION

All configuration of Lightcloud Blue products may be performed using the Lightcloud Blue mobile app. Visit our website for user guides, how-to videos, and other helpful tips on how to use the Lightcloud Blue system and features.

EMERGENCY DEFAULT BEHAVIOR

If there is a power loss, the Lightcloud Blue light will turn on at its last known ON state when power is restored. This can be adjusted in the app to last state, whether on or off.

RESET TO FACTORY SETTINGS

The factory reset options will vary by device. For more information visit our website.



Lightcloud Blue Resources

INSTRUCTIONS

VAN™ FIELD-ADJUSTABLE INSTALLATION

RAB®

RAB Lighting is committed to creating high-quality, affordable, well-designed and energy-efficient LED lighting and controls that make it easy for electricians to install and end users to save energy. We'd love to hear your comments. Please call the Marketing Department at 888-RAB-1000 or email: marketing@rablighting.com

**** DON'T TOSS IT—RECYCLE IT! MAKE THE SUSTAINABLE CHOICE BY RECYCLING THIS FIXTURE AT END OF LIFE WITH A LICENSED RECYCLING PROVIDER. ****

BATTERY BACKUP MODELS

WIRING (120-277V only)

CAUTION: FOR BATTERY BACKUP FIXTURE. Voltage can be present in **BATTERY**. To prevent high voltage from being present on output leads, Inverter connector must be open. Do not join **BATTERY** connector until installation is complete.

NOTE: Make sure that the necessary branch circuit wiring is available. An **UNSWITCHED AC** source of power is required. The emergency driver must be fed from the same branch circuit as the LED driver. Reference Fig. 7 for wiring diagram.

CAUTION: Do not use any supply voltage other than 120-277V. 50/60 Hz.

Battery Backup models are not available for 480V.

1. Connect **UNSWITCHED HOT** fixture lead to **HOT AC** supply line.
2. If using an **UNSWITCHED** circuit, connect **UNSWITCHED** and **SWITCHED** lines together.
3. If using a **SWITCHED** circuit, connect **SWITCHED HOT** lead to the switch.
4. For 0-10V dimming, connect **DIM (+)** purple and **DIM (-)** pink leads to 0-10V dimming connection.
5. All unused leads must be capped and insulated.
6. After installation is complete connect the battery as shown in Fig. 17.
7. When power is on, the fixture should be on and the **CHARGING INDICATOR LIGHT** should illuminate to indicate the battery is charging.
8. Once the **BATTERY** has charged for at least one hour, a short duration test may be performed by pressing the **Test Button** as shown in Fig. 8.
9. After the battery has charged for 24 hours, a long duration test can be performed by disconnecting power to the fixture.

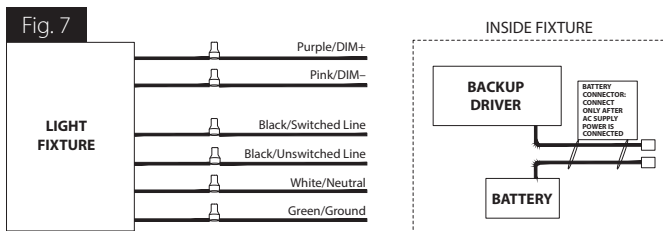

OPERATION

1. When AC power is applied the charging indicator light is illuminated indicating that the **BATTERY** is being charged.
2. When power fails the standby power automatically switches to emergency power (*internal battery*) operating at reduced illumination.
3. When AC power is restored the emergency driver automatically returns to charging mode.

MAINTENANCE

Although no routine maintenance is required to keep the emergency driver functional, it should be checked periodically to ensure that it is working. The following schedule is recommended:

1. Visually inspect the charging indicator light monthly. It should be illuminated
2. Test the emergency operation of the fixture at 30-day intervals for a minimum of 30 seconds.
3. Conduct a 90-minute discharge test once a year. Fixture would operate at reduced illumination for a minimum of 90 minutes.

TROUBLESHOOTING

1. Be sure the fixture is grounded properly.
2. If the charging indicator light does not illuminate after pressing and releasing the **Test Button** (Fig. 8), check power and check if battery is connected properly.

Fig. 8

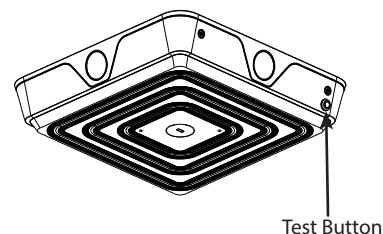

RAB®

© 2026 RAB LIGHTING Inc.

Easy Answers

rablighting.com
Visit our website for product info

Tech Help Line
Call our experts: 888 722-1000

e-mail
Answered promptly - tech@rablighting.com

Free Lighting Layouts
Answered online or by request